

MY NEW REGENERATION of ENERGY

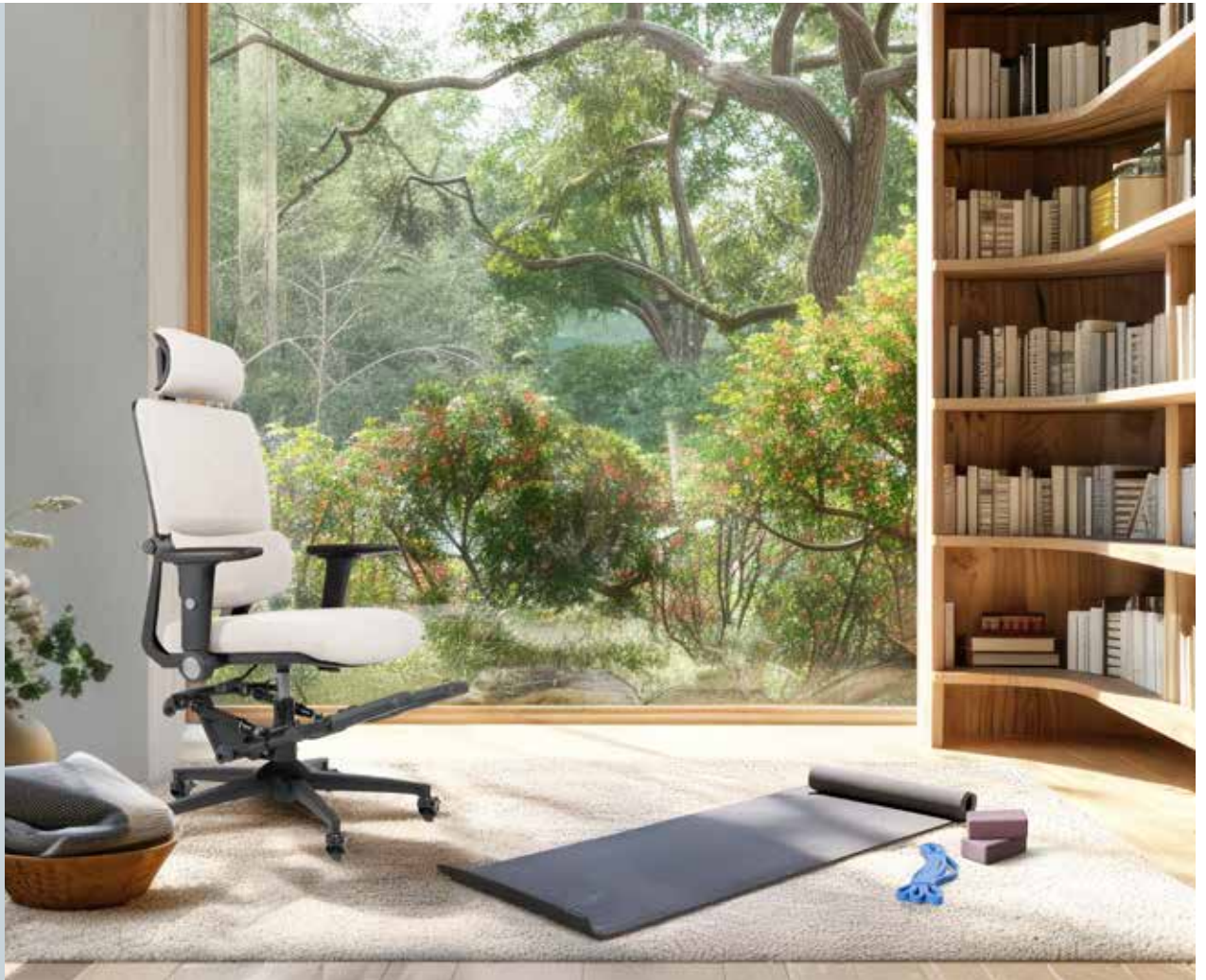

# MY SMARTFIT CHAIR

USER MANUAL

MY  
**SMARTFIT**  
CHAIR



SCAN ME FOR MORE INFO

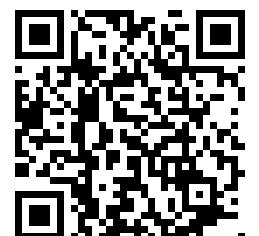

# MySmartfit Chair

We created "MySmartfit Chair" because to the ease of having Pilates-evolved technology in a chair where you spend several hours of your day. Whether you work from home or at a company, are an entrepreneur, employee, student, or someone who spends time on the computer or at a desk, "MySmartfit Chair" is an excellent option for improving your health while sitting in style and comfort.

## WHAT IS PILATES?

Pilates is a movement and training approach that emphasizes core control as a priority in any activity to rectify posture and musculoskeletal balance. With a strong 'core', which includes the abdominal, lower back and side, pelvic floor, and diaphragm muscles, the body's movement, force generation, and supporting postural muscles are more aligned and sensitive to training and functional conditioning.



# Index / Content

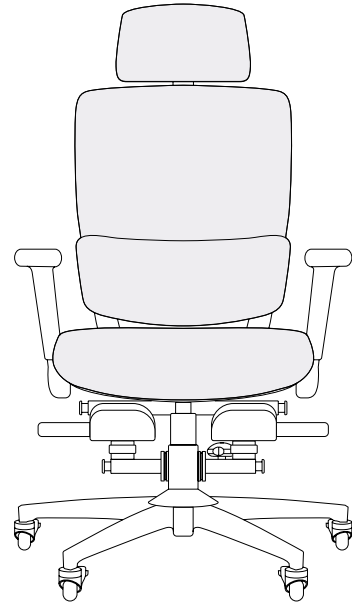

Introduction	04
Safety Precautions for Usage	05
Matters needing attention	09
General Advice for Maintenance	10
Introduction to Pilates Exercises	11
Categories of Movements	17
Section 1 - Seated Exercises	21
Section 2 - Standing Exercises	41
Section 3 - Kneeling Exercises	65
Section 4 - Flooring Exercises	85

# INTRODUCTION

Congratulations on making a better decision for your health and comfort. This user guide will go through the features of the MySmartfit Chair, how to care for it, and most importantly how to use it safely and successfully.

Many people are now discussing the negative effects of extended sitting, and it has even been labeled “the new smoking”, implying that it is damaging to your health equivalent to smoking cigarettes. These impacts are both postural and physiological - impacting muscle, ligament and joint positions, as well as placing pressure on blood and lymphatic circulation, and primarily result from a lack of movement in these areas.

We created "MySmartfit Chair" because to the ease of having Pilates-evolved technology in a chair where you spend several hours of your day. Whether you work from home or at a company, are an entrepreneur, employee, student, or someone who spends time on the computer or at a desk, "MySmartfit Chair" is an excellent option for improving your health while sitting in style and comfort.

Designed to make it easier to incorporate frequent and effective movement throughout your day, even while seated, you can reduce the detrimental effects of prolonged sitting.

A clean and comfortable environment, adequate nutrition, enough quality sleep and rest, recreational and social satisfaction, emotions of personal value and contribution, and of course, a balance of movement and exercise are all necessary for a healthy body at any age. Your customized MySmartfit Chair is now an important element of that mission statement to improve health. Excellent work.



# SAFETY PRECAUTIONS FOR USAGE

## INSTRUCTIONS ON CHAIR SAFETY AND USAGE

### 1 - Opening and closing the pedals

When using the chair as an office-style chair, make sure the pedal extensions (hence referred to as pedals) are stored under the seat. To exercise, do the following steps to bring the pedals out: i) Locate the black knob on the exterior of the pedal arm about 1/3 of the way down; ii) Push the black knob and pedal arm toward the floor with one hand; iii) Fully open the pedal platform with the other hand; iv) Gently release the pedal arm and black knob to the starting position. Repeat on the other side. To close the pedals, repeat the procedure, carefully controlling the position of the pedal arm with the black knob to safely fold back the pedal.

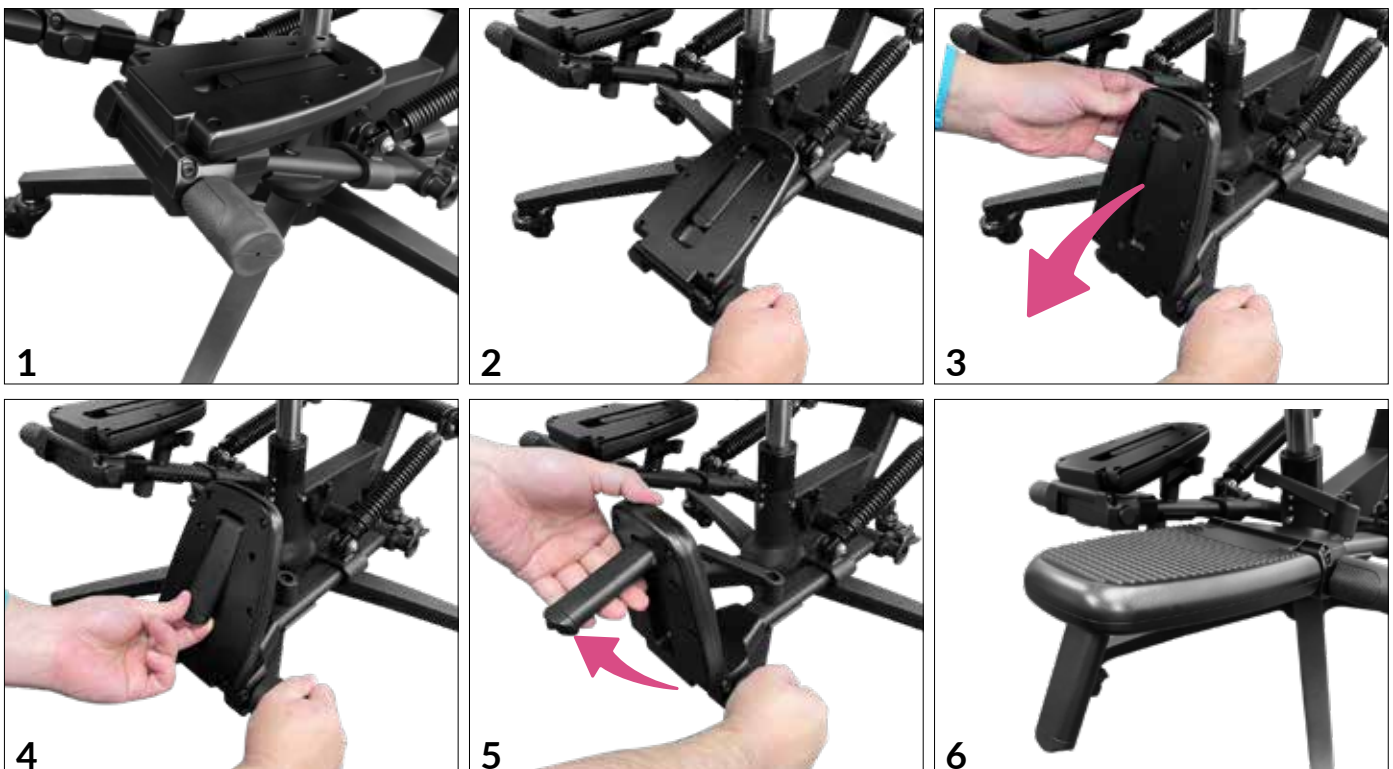

\* Repeat the above steps on the other side

## 2 - Adjusting the spring setting

Each pedal has two springs attached to the pedal arm, for a total of four springs. Only the exterior springs are adjustable, and each spring has two settings: High (heavier resistance) and low. (lighter resistance)

To adjust the spring, first ensure that the pedal extension is out and ready for use. (as described above) Take the large black knob and gently raise it up to alleviate strain on the spring. Find the spring slider's small black button and pull it outwards. The spring slider can then be moved up and down about 1.25 inches to find the desired location hole. Let go of the small black knob and check that the pin clicks into the hole. By jiggling the slider, you can ensure that it is securely in place.

The springs on the outside are adjustable, and each spring has two settings – **high (heavier resistance) and low. (lighter resistance)** Pull spring knob out. Then move up or down to adjust and position higher or lower hole.

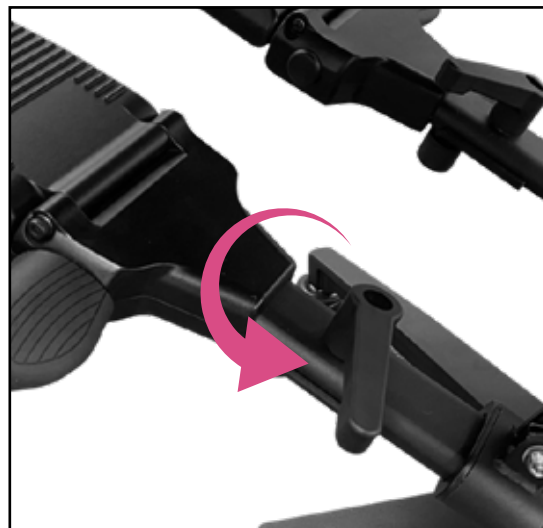

### 3 - Locking split pedals together

Because many of the exercises on the MySmartfit Chair use the pedals in split mode, which allows for more rotation and movement options, we recommend leaving them in split mode in general. For activities that demand more resistance, (such as standing leg pumps) the pedals can be locked together. This will activate all four springs on each pedal. To begin, make sure that both pedal spring settings are in the same hole (high or low). Then, at the back base of the chair, locate the large black knob on the pedal arm axle that runs parallel to the ground. Tighten this knob tightly clockwise to lock the two pedals together. There is a tiny bend in one pedal relative to the second pedal due to the design; this is normal and will not affect use or safety. Turn the same knob counter-clockwise to separate the pedals and ensure they operate individually and smoothly.



### 4 - Moving the chair

Normal office chair wheels could not be utilized on this item to ensure safety during exercise mode. To move the MySmartfit Chair, stand behind it with one foot on the flat base-stand at the black knob that connects the pedals. Grip either side of the chair near the top and gradually lean back to a 45-degree angle. Remove your foot and slowly wheel to your destination. Return your foot to the same foundation position and slowly lower the chair to a steady upright position.



Moving



Exercise Mode

## **DO NOT MODIFY**

The unique MySmartfit Chair spring-loaded foot pedal technology is safe to use with the chosen loading. Any alterations to the construction void the warranty.

## **WEIGHT LIMIT**

The chair is intended for normal use by anyone weighing less than 300 lb.

## **USAGE LIMITATIONS**

We only advocate the exercises indicated in this MySmartfit Chair user handbook. Standing or kneeling on the chair is not recommended.

## **MISCELLANEOUS**

### **■ PETS**

If you have pets, please consider using a cover to prevent chewing, scratching, and material damage. When operating the pedals, keep pets safely away from the chair.

### **■ CHILDREN**

Before using a chair, children and teenagers should be thoroughly trained in its proper use. We do not recommend that children under the age of 12 utilize the chair without adult supervision.

When utilizing the workout mode, take care to keep toddlers and children away from the device.

# Matters needing attention

<b>⚠ CAUTION</b>	
Weight on this product should not exceed 300 lbs.	
<b>⚠ WARNING</b>	
Any exercise can present a health risk. Consult a physician before beginning any exercise program with this equipment. This is especially important if you have never exercised before, are pregnant, or suffer from any health problem. If you feel faint or dizzy, immediately discontinue use of this equipment.	
Serious bodily injury can occur if this equipment is not assembled and used correctly. Make sure that all bolts are tightened prior to each use. Keep others and pets away from equipment when in use.	
Follow all safety instructions in this manual.	
<b>⚠ Cancer and reproductive harm    <a href="http://www.P65Warnings.ca.gov">www.P65Warnings.ca.gov</a></b>	
This product is for home /office use only. Do not use it in institutional or commercial applications. Failure to follow all warnings and instructions could result in serious injury or death.	
<b>SAFETY INSTRUCTIONS</b>	
<b>To reduce the risk of serious injury, read the following safety instructions before using the My Smartfit Chair.</b>	
<b>01</b>	Save these instructions and ensure that exercisers read this manual prior to using the My Smartfit Chair for the first time.
<b>02</b>	Make sure that you are using the bands in a manner that reduces your risk of injury. Wear eye protection such as goggles or glasses while using resistance bands for exercise.
<b>03</b>	The My Smartfit Chair should only be used after a thorough review of the Owner's manual. Make sure that it is properly assembled and tightened before use.
<b>04</b>	We recommend that two people be available for assembly or moving of this product.
<b>05</b>	Always keep children and pets away from the My Smartfit Chair at all times.
<b>06</b>	Do not operate the My Smartfit Chair on loose rugs or uneven surfaces.
<b>07</b>	Make sure that adequate space is available for access to and around the My Smartfit Chair.
<b>08</b>	Before using, inspect the My Smartfit Chair for worn or loose components, and securely tighten or replace any worn or loose components prior to use.
<b>09</b>	Choose the intensity that fits your strength and flexibility level. Know your body's limits and use this product within them.
<b>10</b>	Do not wear loose or dangling clothing while using the My Smartfit Chair.
<b>11</b>	Be careful to maintain your balance while using, mounting, dismounting the My Smartfit Chair, loss of balance may result in a fall and serious bodily injury.
<b>12</b>	The My Smartfit Chair should not be used by people weighing over 300 lbs
<b>13</b>	The My Smartfit Chair should only be used by one person at a time.
<b>14</b>	Move the pedals upward and downward in a controlled manner. Maintain tension on the pedals so that they do not move quickly and strike your body or other objects.
<b>15</b>	Over exercising may result in serious injury or death. If you feel faint, if you become short of breath, or if you experience pain while exercising, stop immediately and consult your physician or medical provider.

ACCESS YOUR ONLINE  
**ASSEMBLY**



# GENERAL ADVICE FOR MAINTENANCE

**To get the best out of MySmartfit Chair, we recommend the following:**

## **Regular Checks:**

please check the screws in the chair base and arm rests are appropriately tight after the first month of use, and regularly every 2 months to ensure safe functioning.

## **Cleaning**

We recommend the following to get the most out of MySmartfit Chair:

Please clean all non-metallic surfaces of the chair with a soft cloth and warm soapy water. If you stain the cloth by accident, please use "PU LEATHER CLEANER" to help remove the stain.

To remove dust from all metallic surfaces, (springs, pedals, frame) use a dry soft cloth. Clean the spring slide bars on a regular basis with a soft, dry cloth to minimize dust buildup that can affect smoothness. Do not use oil. For lubrication use "PU LEATHER CLEANER". Avoid using "WAXES," as these solvents may harm the material.

## **Rubber Bands**

Check the rubber bands for any nicks or damage before each usage. Bands have a limited lifespan that is influenced by the amount utilized, environmental variables, (heat and humidity) and storage techniques.

Cleaning your bands with warm soapy water and then rinsing them will help them last longer. Consider a small coating of talc or chalk dust after drying with a standard hand towel. Avoid any movements bringing bands toward eyes or face.

## **Storage**

When not in use, avoid leaving the chair in direct sunlight. If you will not be using the chair for a few days, we recommend covering it with a cloth or towel to avoid dust or damage.

To maintain the cushions and material, do not stack items on the chair during storage.

# INTRODUCTION TO PILATES EXERCISES

Pilates is a movement and training approach that emphasizes core control as a priority in any activity to rectify posture and musculoskeletal balance. With a strong "core," which includes the abdominal, lower back and side, pelvic floor, and diaphragm muscles, the body's movement, force generation, and supporting postural muscles are more aligned and sensitive to training and functional conditioning.

The Pilates Method relies heavily on movement principles. It is critical to remember these concepts when using the MySmartfit Chair. All the exercises in our repertoire are taught in accordance with these guidelines. Let us begin with a brief overview of the six principles of Contrology. (Joseph Pilates' original name for the approach)

## ■ Principle 1 - Breathing

The consistent use of breath during Pilates movements has various benefits, including increased energy through greater oxygenation, improved core muscle function, and natural movement. The proposed breathing sequences are not rigorous, but you are encouraged to follow them as closely as possible. It is preferable to breathe in via the nose and out through the mouth.

## ■ Principle 2 - Centering

This might also be referred to as "alignment," as we want to produce the perfect position of each portion of the body to generate an upright, easy-to-function in posture. Bringing all parts of the body back to the center line starts with the pelvis and moves up through the spine, neck and head, and down via the hips, knees, and feet. The more aligned or centered a body is, the less energy it takes to resist gravity, resulting in less fatigue and stiffness at the end of the day.

### ■ Principle 3 – Flow

Every joint and limb must be completely integrated into a moving whole. This is the goal of Pilates practice, as well as the Method's approach to integrating the entire body into effective, real-world movement. For an example, when you do something as basic as lifting your leg to go up a stairwell, multiple muscles must initially fire to stabilize the ankle and hip, the side, back and front of the spine, and even the neck and head. The efficiency with which this preparation and transition to movement is accomplished lends elegance and poise to every action. This reduces overall stress, as a result, wear and tear on the joints and cartilage.

### ■ Principle 4 – Concentration

By emphasizing proper breath, centering, and smooth flow in each exercise, you infuse your entire being with a profound sense of concentration. This inner focus brings a meditative and revitalizing quality to your practice. Becoming attuned to your body's sensations (body awareness) slows down brain waves, allowing them to enter the creative alpha frequency and find respite from the active, often stressful beta frequencies. Just dedicating a few minutes to enhancing posture, moving your body, and centering your breath can work wonders for sustaining energy throughout your day.

### ■ Principle 5 – Control

We live in a fast-paced environment, and we sometimes lack the patience or calmness to deal with our circumstances. We achieve a sensation of 'being in control' through control, particularly of our muscles and bones, and this emanates a calmer and more deliberate presence to our demeanor. The only thing we truly have control over in life is ourselves. Pilates focuses on smooth and regulated movements, which has benefits that translate to many aspects of work and daily life.

### ■ Principle 6 – Precision

Precision requires investing time and attention to build a movement as pure and as aligned with your body's form and the obstacles it faces. (such as an exercise) You may have noticed how the Pilates concepts all build upon one another. Our goal is to bring all these principles under the control of the subconscious mind, where your body and energy systems will naturally realign to get you to a better level of function.

## Understanding the spine

The spine is formed of 24 moving bones: 7 in the neck, 12 in the thoracic, and 5 in the lumbar, as well as the immobile bones of the sacrum, pelvis, and skull. The spine's biological job is to keep our heads elevated and to protect and distribute the nerves that go from the brain and spinal cord to the rest of the body. Every joint contains nerves that extend out in an astonishing tapestry of directions. Compressed vertebrae mean compressed nerve roots, as well as a higher chance of disc injury between each vertebra.

The spine has three basic planes of movement: front to back, side bending, and rotation. Sagittal, coronal, and transverse are the technical terms for these. Pilates exercises are frequently intended to address each of these planes separately at first, before building integrated multiple plane motions. As a result, the exercise descriptions progress from the simplest and safest (named "Foundational Movements") to the more strenuous and dynamic "Integrated Movements."

If you have had a recent or previous major spine injury and know that particular postures give you pain or continuous difficulties, you should avoid doing certain poses without the supervision of a trained instructor. The good news is that your body will adapt and enhance its functional abilities as you perform the Foundational Movements throughout weeks and months. Discs, cartilage, and bones heal with good nutrition and activity, so keep a healthy you in mind. You should avoid doing certain poses without the supervision of a trained instructor and approval from your medical provider.



## Understanding the spine

There are numerous advantages to do the exercises and movements on the MySmartfit Chair on a regular basis. It is critical to remember that if you already have discomfort, imbalance, or a chronic injury in an area that took months or even years to develop. We must "re-develop" those structures to bring them back into alignment, which might require some time. However, it is important to note that this time may increase slightly with age. Patience and persistence are the two most important attributes necessary for this transformation. Many customers have discovered that a chronic pain can take three, six, or even twelve months to significantly improve. Follow solid advice and stick to it.

---

## BODY AREAS

The exercises performed on the MySmartfit chair are divided into five categories: seated, standing, kneeling, floor, and resistance band. Each category takes a unique approach to working the various parts of your body. We have separated the body into four major regions so that you can navigate the feelings in your body to the sort of movements to develop that area while learning the moves. The following provides an overview of the area as well as the benefits of working in certain places.

### ■ Lower body (legs)

The foot, ankle, lower leg, (calf and shin) knee, thigh and hamstrings, hip joint, and gluteal muscles (butt) are all included in this area. The following are some of the advantages of MySmartfit Chair movements for this area:

- Helps with sciatica, tight hamstrings, and hip discomfort by releasing hip, gluteal, and hamstring strain and pressure.
- Increases circulation and relaxation in the calf and lower leg muscles, decreasing the risk of deep vein thrombosis, (DVT) varicose veins, swollen ankles, and foot and knee pain.
- Improves hip, knee, and ankle alignment and strength (helping functional activities like walking, jogging, squatting, and cycling) as well as balance and standing posture.

## ■ Core and Lower Back

This is known as the "lower-mid torso" and encompasses the pelvis, lumbar spine up to the lowest rib, sides, (waist) and the entire belly area from pubic bone to solar plexus. The following are some of the advantages of MySmartfit Chair exercises for this area:

- Core muscles are much more than simply your "abs" and include movers and stabilizers that wrap around your lower-mid torso. This network supports your center of gravity (just behind and below your navel) and helps your upper and lower bodies to coordinate efficiently. A strong core results in better balance, a stronger foundation of support, and the development of power, as well as less lower back pain and better posture.
- The lumbar vertebrae and the sacrum-pelvis link are referred to as the lower back. Back pain accounts for 40% of all missed workdays in the United States, and it is the fifth most common reason for doctor visits. Pilates is well-known for improving the condition of the spine and reducing back pain, particularly in the lower back, when performed properly.
- Because of the importance of support, many upper and lower body disorders can be caused by a lack of core strength and endurance. Sciatica and neck discomfort are two examples. These two issues can be addressed or totally remedied by correctly exercising the core over time. The point is that the core is at the heart of the entire body's functioning ability.

## ■ Spine and Neck

- The thoracic spine, which includes the 12 vertebrae to which your ribs join, affects breathing capacity and lung function. Sitting for lengthy periods of time usually causes strain in the mid back, which can impair joint structures and disc integrity over time. Thoracic spine health is also crucial in preventing osteoporosis as we age.
- The cervical vertebrae are the tiniest and most fragile of the spine's bones. These 7 bones, with proper alignment, strength, and flexibility, will allow the head to sit more comfortably in position. Neck areas are closely linked to thoracic spine mobility as well as shoulder strength and flexibility. These problems are deteriorating because of excessive use of technology such as cell phones and laptops.

## ■ Shoulders and Arms

- Sitting for long periods of time, especially while using a computer or writing/working at a desk, causes the weight of our arms and shoulders to pull our upper body forward, causing additional tension and stress to the neck and back muscles and ligaments. This can have a negative impact on posture over time by putting pressure on the digestive organs, heart, and lungs, potentially diminishing their functional capacity.
- Forearm, wrist, and hand muscles require circulation and flexibility to function properly. Stronger arms and shoulders can be developed with healthy hands. Grip strength, believe it or not, is a significant indicator of longevity - those who live longer tend to have stronger grips. A stronger hand-arm system implies you can live a more active life. We know you can keep moving.



# CATEGORIES OF MOVEMENTS ON MYSMART FIT CHAIR

## Introduction to Pilates Exercises

Pilates is a movement and training approach that emphasizes core control as a priority in any activity to rectify posture and musculoskeletal balance. With a strong "core," which includes the abdominal, lower back and side, pelvic floor, and diaphragm muscles, the body's movement, force generation, and supporting postural muscles are more aligned and sensitive to training and functional conditioning.

### ***SE-* Seated**

Seated exercises are performed in two positions: facing front and facing side, allowing for easy leg, hip, and spine relaxation.

### ***ST-* In Standing**

In standing, facing back (toward the chair) and facing side provide a variety of alternatives for improving leg strength, balance, and spinal control.

### ***KN-* Kneeling**

Facing back and side, with a mat beneath the knees, provides excellent spinal release positions as well as core and pelvic floor stimulation.

### ***FL-* Floor**

Using an exercise mat allows for a variety of seated exercises targeting the front, back, and sides, as well as lying face down in a swimming position.

### **Resistance Band**

There are numerous ways to use the referenced bands, which have four attachments, (two on each side) to give a more dynamic and rewarding strength training experience.

\*Exercise bands sold separately.

## Training Regimens

Towards the conclusion of the manual, you will come across a concise reference guide featuring specific training regimens. Whether you have a short window of two minutes or a more extended period, our guide accommodates your needs. It offers quick hip or shoulder releases as well as comprehensive whole-body realignment exercises. We recognize that certain exercises may be more suitable in different settings, such as a crowded office or while wearing office attire and have curated the guide accordingly to best serve the requirements of MySmartfit Pilates chair users, including yourself. It is recommended to only use light or moderate strength closed-loop resistance bands with the chair.

## Exercise Chart for MySmartfit Chair usage

	<i>SE</i>	<i>ST</i>	<i>KN</i>	<i>FL</i>
	SEATED	STANDING	KNEELING	FLOOR
FOUNDATIONAL	<u>SE-1</u> Seated Knee Lifts	<u>ST-1</u> Standing Press Down Front	<u>KN-1</u> Kneeling Rolldown	<u>FL-1</u> Spine Stretch Forward
	<u>SE-2</u> Seated Side Bend	<u>ST-2</u> Standing Press Down Side		<u>FL-2</u> Wide-legged Spine Stretch Forward
	<u>SE-3</u> Seated Rolldown	<u>ST-3</u> Achilles Stretch	<u>KN-2</u> Kneeling Side Bend	<u>FL-3</u> Long Back Arms
		<u>ST-4</u> Standing Rolldown		<u>FL-4</u> Swimmer
INTEGRATED	<u>SE-4</u> Seated Alternating Spine Rotation-1	<u>ST-5</u> Standing Press Down Front (variation)	<u>KN-3</u> Kneeling Alternating Arm Push Down	<u>FL-5</u> Wide-legged Alternating Arm Twist
	<u>SE-5</u> Seated Alternating Spine Rotation-2	<u>ST-6</u> Side-standing	<u>KN-4</u> Rolldown Rotation	
	<u>SE-6</u> Side-seated Waving	<u>ST-7</u> Standing Alternating Arm Push Down	<u>KN-5</u> Kneeling Mermaid to Front Wave	<u>FL-6</u> Advanced Swimmer
		<u>ST-8</u> Standing Alternating Arm Push Down Rotation		
			KN-6-KN-9 are done standing	
BAND	<u>SE-7</u> Band Shoulder Press (double and single) Hand	<u>ST-9</u> Upright Row Series	<u>KN-6</u> Donkey Kicks	<u>FL-7</u> Full Body Roll Down
	<u>SE-8</u> Band Front Overhead Raise	<u>ST-10</u> Bicep Curls	<u>KN-7</u> Standing Lateral Leg Raises	<u>FL-8</u> Resistance Band Full Body Roll Up
	<u>SE-9</u> Seated Band Bent Arm Lateral Raise	<u>ST-11</u> Ski Squats	<u>KN-8</u> Rear Straight Leg Raises	<u>FL-9</u> Resistance Band Rear Delt Row
		<u>KN-9</u> High Knee March	<u>FL-10</u> Resistance Band Chest & Overhead Press	<u>FL-11</u> Kneeling Side Bend

## Suggested Programs with Body Area focus

To focus on specific areas, the following exercises in the order given are most suitable.

**1**

### Arms and Shoulders

• RELEASE 1	SE-2 ▶ SE-3 ▶ SE-4 ▶ ST-4
• RELEASE 2	KN-1 ▶ KN-2 ▶ FL-3 ▶ FL-4
• STRENGTHEN	SE-7 ▶ SE-8 ▶ ST-9 ▶ FL-9

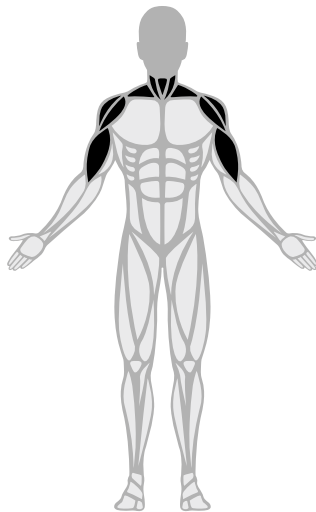

**2**

### Stomach and Sides

• ACTIVATE 1	SE-2 ▶ SE-3 ▶ SE-5 ▶ KN-1 ▶ KN-5
• ACTIVATE 2	ST-4 ▶ ST-8 ▶ KN-2 ▶ FL-1 ▶ FL-5
• STRENGTHEN	KN-8 ▶ KN-1 ▶ FL-7 ▶ FL-11 ▶ FL-8

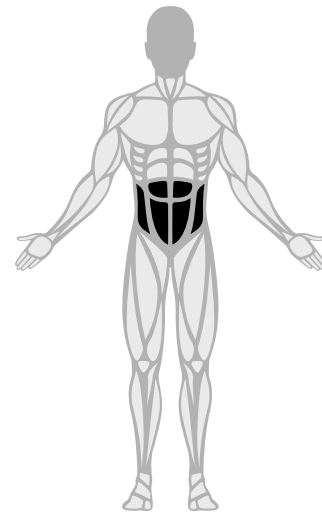

**3**

### Lower and Upper back

• RELEASE 1	SE-1 ▶ SE-2 ▶ SE-3 ▶ SE-4 ▶ SE-5 ▶ SE-6
• RELEASE 2	KN-1 ▶ KN-4 ▶ KN-2 ▶ ST-4 ▶ ST-7
• STRENGTHEN	ST-11 ▶ KN-9 ▶ FL-2 ▶ FL-7 ▶ FL-11

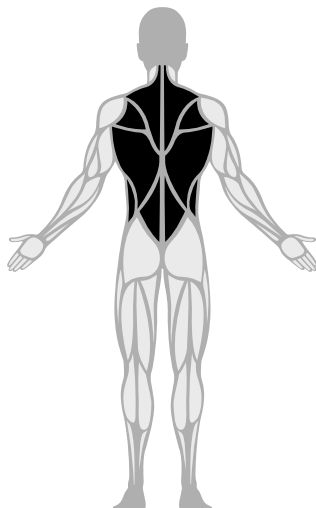

**4**

### Legs

• ACTIVATE	SE-1 ▶ ST-1 ▶ ST-2 ▶ ST-3 ▶ ST-5
• RELEASE	KN-1 ▶ KN-2 ▶ FL-1 ▶ FL-2 ▶ FL-5
• STRENGTHEN	ST-11 ▶ KN-7 ▶ KN-8 ▶ KN-9 ▶ KN-6

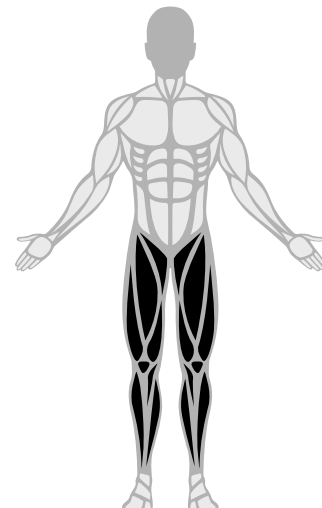

# MY SMARTFIT CHAIR

MY NEW  
REGENERATION of ENERGY

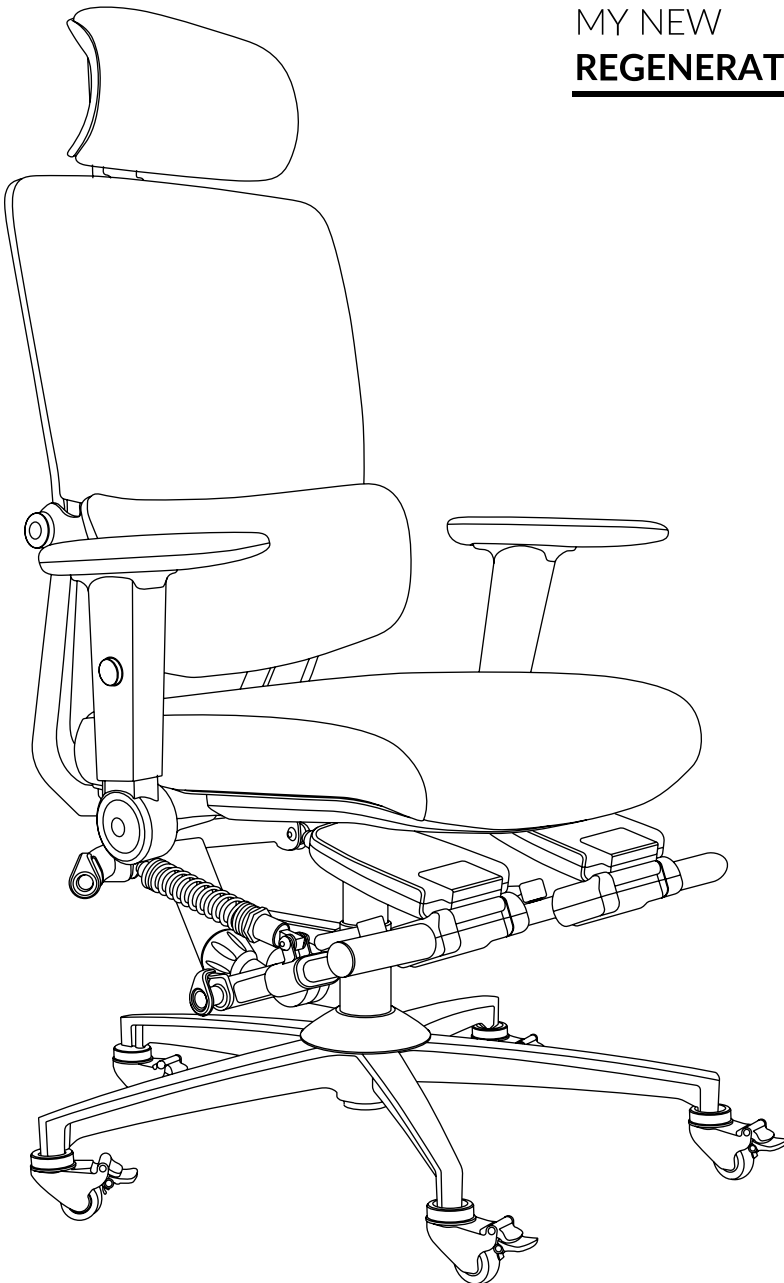



**SECTION 1**  
**SEATED EXERCISES**

	<b>FOUNDATIONAL</b>
<i>SE-1</i>	Seated Knee Lifts
<i>SE-2</i>	Seated Side Bend
<i>SE-3</i>	Seated Rolldown
	<b>INTEGRATED</b>
<i>SE-4</i>	Seated Alternating Spine Rotation-1
<i>SE-5</i>	Seated Alternating Spine Rotation-2
<i>SE-6</i>	Side-seated Waving
	<b>BAND</b>
<i>SE-7</i>	Band Shoulder Press (double and single) Hand
<i>SE-8</i>	Band Front Overhead Raise
<i>SE-9</i>	Seated Band Bent Arm Lateral Raise

# SE-1

## SEATED EXERCISES

### FOUNDATIONAL

### Seated Knee Lifts

#### SPRING POSITION

#### HIGH

Front half of the chair, balanced on sitting bones.

#### BODY POSITION

Heels on pedals.

Back upright, neck straight, eyes looking forward.

#### STARTING POSITION

Sit up tall on the chair.

Feet flat on the pedals.

Back is upright, your neck straight, and your gaze forward.

#### MOVEMENT

**START** – Extend your arms out to the sides at shoulder height, palms facing down. Sit tall with both pedals on the ground.

**MIDDLE** – Inhale slowly and deeply as you lift your knees as high as comfortably possible without compromising your posture. If you need to lean back, it indicates that you have reached the end of the upward motion.

**END** – Exhale, draw in your belly bottom, and lower your feet back down until they reach. Avoid leaning forward. Repeat 10 to 15 repetitions.

#### SEQUENCING

10-15 repetitions.

Slow and even speed throughout. (2-4 seconds up and 2-4 seconds down)

Focus on deep, long breathing creating a slow controlled movements. Avoid leaning forward and keep gaze long.

#### VARIATIONS

**“Seated Alternating Leg Lifts ”** – Lift your right leg and then lower it slightly above the floor. Switch to the left leg and continue alternating legs.

**“Seated Goal Post”** – Raise your arms high above your head.  
**“Seated Spine Twist”** – Starting position genie arms. Rotate your upper body to the right, keeping your hips and lower body stable. Lift your legs up as you return to the center and then lower your legs as you rotate to the left. Continue alternating sides.

Start Position



Middle Position



Seated Alternating Leg Lifts



Seated Goal Post



Seated Spine Twist



# SE-2

## SEATED EXERCISES

### FOUNDATIONAL

## Seated Side Bend

### SPRING POSITION

**LOW or HIGH**

**Arm rest in back position**

### BODY POSITION

Side facing, sitting forward on chair.

Heel of hand reaching toward pedal.

Other hand behind head or to straight to the side.

### MOVEMENT

**START** – Inhale as you slowly lean sideways until hand reaches the pedal and ensure a firm grip.

**MIDDLE** – Exhale as you begin to push the pedal down. (you may not go very far down!) Feel the opening of the ribs and armpit on the opposite (up) side and aim to reach that area upwards toward the roof. Always keep "BOTH" sitting bones on the chair.

**END** – At the bottom of your downward movement, begin the ascent with an inhale and stack all the way back to upright position.

### SEQUENCING

6-8 repetitions each side.

Slow and even speed throughout. (2-4 seconds up and 2-4 seconds down)

At the top of the return, hand can stay on pedal (maintain some side bend) or can leave pedal as you sit up fully.

### VARIATIONS

**“Side-Breathe”** – Stay at the lowest point of the side bend and breath in deeply 3-5 times to expand the ribcage on the high side.

**“Wave”** – Stop at the lowest point and arc the top arm up and down in the side plane like you are waving to an airplane.

Start Position



Middle Position



Mermaid Side Bend



# SE-3

## SEATED EXERCISES

### FOUNDATIONAL

## Seated Rolldown

#### CAUTION

**Lumbar disc herniation**

#### SPRING POSITION

**LOW or HIGH**

#### BODY POSITION

Sitting on front 1/3 of the chair, knees wide, and feet stable on ground.

Hands on pedals.

#### MOVEMENT

**START** - Inhale to sit tall and hinge forward until hands reach the pedals.

**MIDDLE** - Exhale and pull the belly in as you smoothly push the pedals down by tucking the chin in and curling the upper spine and head downwards.

**END** - Inhale at the bottom while you hold the stretch, then exhale so slowly stack back up.

#### SEQUENCING

8-15 repetitions.

Slow. (5 seconds down, 5 seconds hold, 5 seconds up)

Fast. (1-2 seconds down and 1-2 seconds up)

Focus on pulling belly in to support lumbar spine.

#### VARIATIONS

**“Straight Back”** - Keep back straight throughout the movement, focusing on hip hinging through the up and down while maintaining active back extensors.

Start Position



Middle Position



Seated Straight Back



# SE-4

## SEATED EXERCISES

### INTEGRATED

## Seated Alternating Spine Rotation-1

### CAUTION

**Lumbar disc herniation**

### SPRING POSITION

**LOW or HIGH**

### BODY POSITION

As with **SE-3 Seated Rolldown**.

### MOVEMENT

**START** - Push both pedals halfway down and stop.

**MIDDLE** - With arms straight, lift one pedal and press the other down. Rotate the head and neck to the same side as the shoulder coming up.

**END** - Reverse the movement by smoothly turning head to other side and allowing arms to change. Pedals cross over in mid-point where you started.

### SEQUENCING

6-8 repetitions each side.

Keep a smooth, long rhythm to the movement.

Inhale and exhale can be varied - inhale turn up, exhale turn back. Or try a double inhale-exhale - inhale left, inhale right, exhale left, and exhale right. Have fun with it and explore.

### VARIATIONS

**“Step-by-Step”** - Alternate each pedal and move up and down as well like walking up a set of stairs. This is like combined the walking with the seated pushdown from foundations.

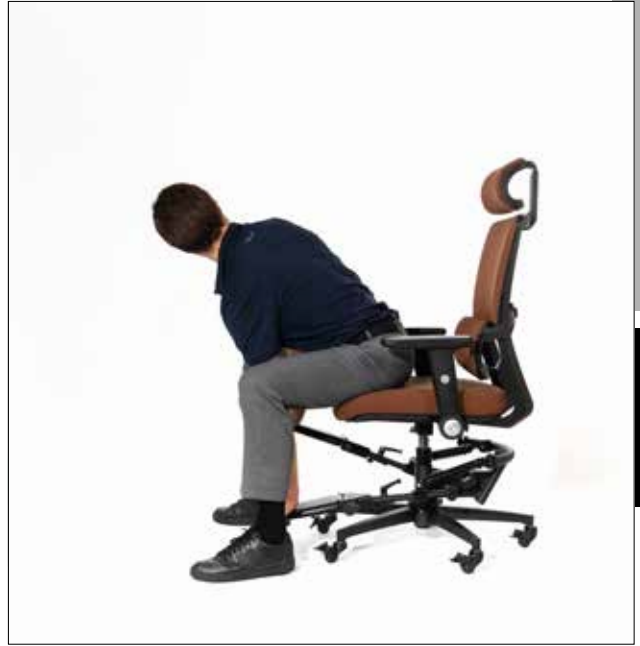
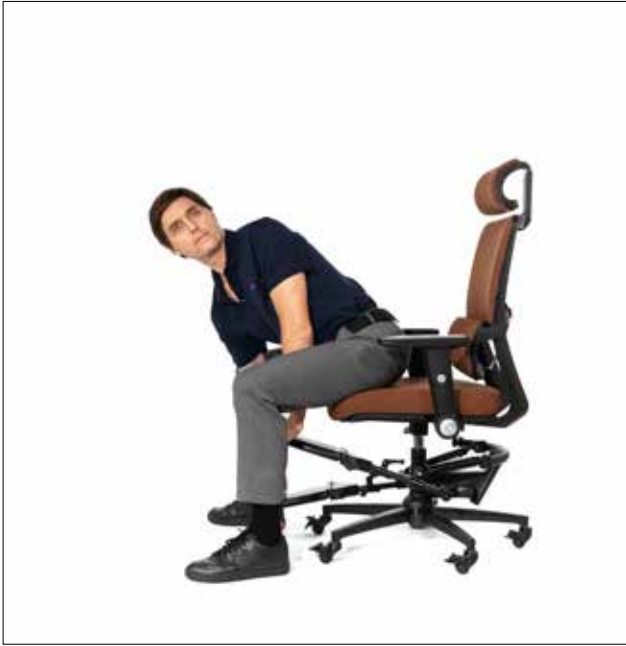

Seated Alternating Arm Push Down

# SE-5

## SEATED EXERCISES

### INTEGRATED

## Seated Alternating Spine Rotation-2

#### CAUTION

**Lumbar disc herniation**

#### SPRING POSITION

**LOW or HIGH**

#### BODY POSITION

As with **SE-3 Seated Rolldown**.

**One hand on opposite pedal, other arm to side or back of head.**

#### MOVEMENT

**START** - Inhale to push pedal down slightly as you rotate the upper body to look toward the side and upwards.

**MIDDLE** - Hold fully rotated position briefly.

**END** - Exhale to return to start position.

#### SEQUENCING

3-5 repetitions each side.

Focus on the smooth rotation of the upper arm and neck. Avoid straining the neck by focusing on torso rotation.

#### VARIATIONS

**"Flossing"** - Stay in the rotated position and then push pedal up and down slightly to floss the spine.

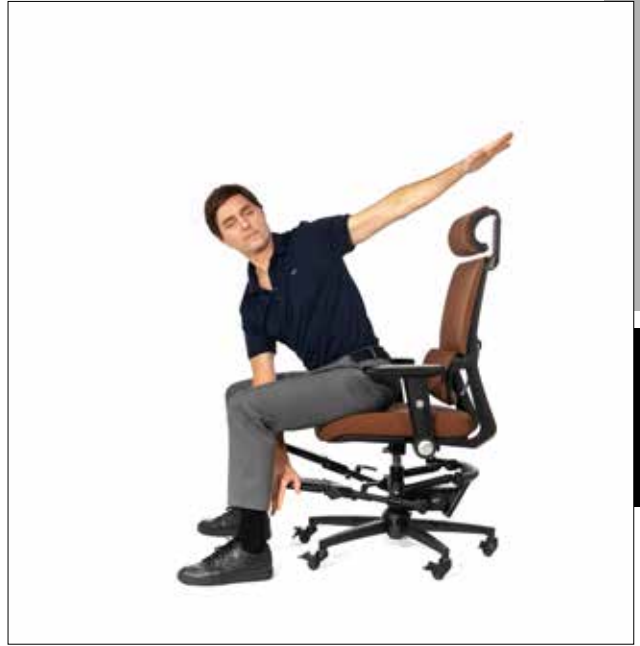

Seated Alternating Arm Push Down with Rotation

# SE-6

## SEATED EXERCISES

### INTEGRATED

## Side-seated Waving

### SPRING POSITION

#### HIGH

Arm rest in back position

### BODY POSITION

As with **SE-2 Seated Side Bend**.

**NOTE** – this is a small movement range.

### MOVEMENT

**START** – As above, as you begin to push down in the side-bend, rotate the top arm down, and around like you are weaving you top hand around your lower elbow.

**MIDDLE** – Allow the pedal arm’s elbow to rotate outwards slightly and imagine you are hugging a big ball, which allows the shoulder blades to open. Keep the belly tucked in and pelvis stable.

**END** – Inhale to unwind yourself back to start position and keep hand on pedal for all repetitions.

### SEQUENCING

3-4 repetitions each side.

The downward range is less than the side bend version. Your focus is on reaching through the rotation of the weave.

### VARIATIONS

**“Side-Breathe”** – Stay at the deepest point of the weave and breath in deeply 3-5 times to expand the ribcage on the high side.

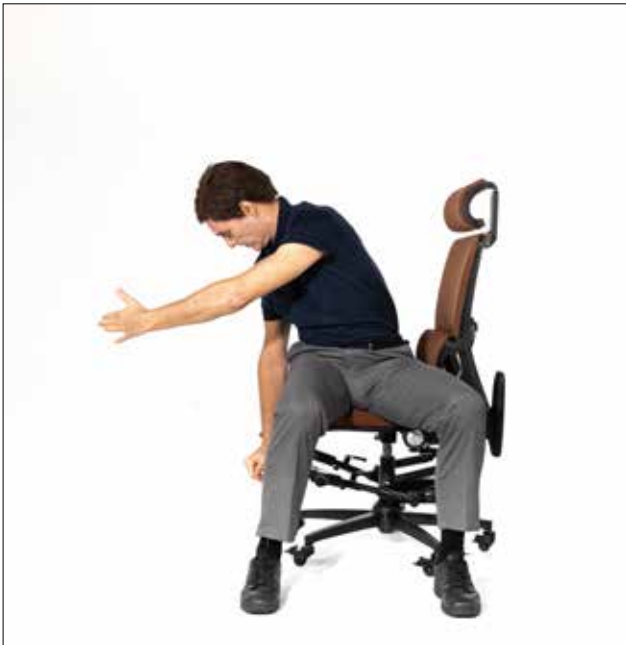
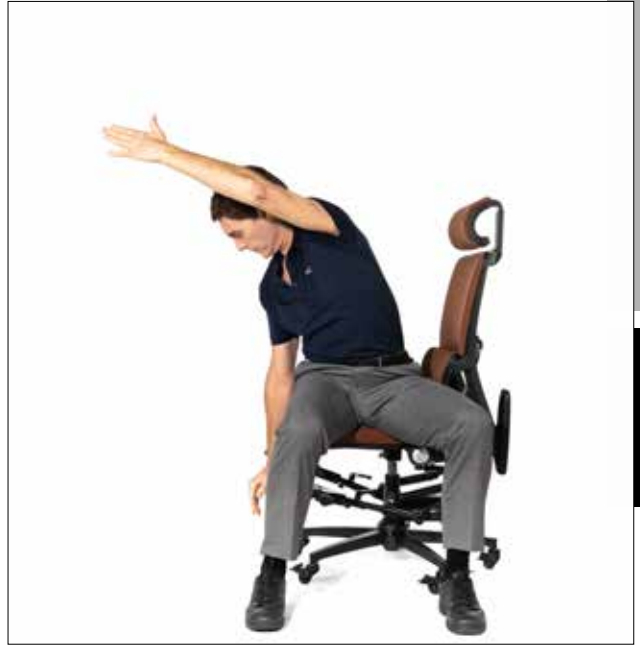

Mermaid Seated to Front Wave

## SE-7

## SEATED EXERCISES

## BAND

## Band Shoulder Press (double and single) Hand

## CAUTION

- **Shoulder impingement – reduce range of motion and load**
- Make sure that you are using the bands in a manner that reduces your risk of injury. Wear eye protection such as goggles or glasses while using resistance bands for exercise.

BAND  
POSITION &  
STRENGTH**ARM RESTS BACK**

**SEAT-SIDE CONNECTORS** – Loop band on left and right connectors.

**MEDIUM OR LIGHT BAND**

Middle or back of chair.

Band crossing front of thighs.

Feet on ground.

Back upright, neck straight, eyes looking forward.

## BODY POSITION

**START** – Grip a single strand of band in both hands at shoulder width apart and palms forward.

**MIDDLE** – Exhale and press upward in a smooth arc toward the ceiling until arms are straight.

**END** – Inhale and lower slowly back to start position beside shoulders.

## MOVEMENT

8-12 repetitions.

Slow and even speed throughout. (1-2 seconds up and 1-2 seconds down)

As hands go up, feel like you are dropping the shoulders down and wide.

## SEQUENCING

**“Reverse Grip”** – Turn palms backward to begin and perform press. (not shown)

**“Side Yawn Press”** - Press with both hands and lean slightly to one side.

**“Single Arm Press”** – Use one arm only to press up and down. Add rotation for variation. (shown below)

## VARIATIONS

Band is not included.

Band Shoulder Press  
Start Position



Middle Position



Band Shoulder Press with Spine Twist



Band Single Arm Shoulder Press

## SE-8

## SEATED EXERCISES

## BAND

## Band Front Overhead Raise

## CAUTION

- **Shoulder impingement – reduce range of motion and load**
- Make sure that you are using the bands in a manner that reduces your risk of injury. Wear eye protection such as goggles or glasses while using resistance bands for exercise.

## SPRING POSITION

**ARM RESTS BACK**

**SEAT-SIDE CONNECTORS** – Loop band on left and right connectors.

**LIGHT BAND**

## BODY POSITION

Middle or back of chair.

Band crossing front of thighs.

Feet on ground.

Back upright, neck straight, eyes looking forward.

## MOVEMENT

**START** – Take a single band in both hands at shoulder width and straight arms with hands near knees.

**MIDDLE** – Inhale and sweep arms slowly upward until overhead.

**END** – Exhale to lower through the arc back to the knees.

## SEQUENCING

6-8 repetitions.

Slow and even speed throughout. (1-2 seconds up and 1-2 seconds down)

As hands go up, feel like you are dropping the shoulders down and wide.

## VARIATIONS

**“Tricep Extension”** – At the top of the action, bend the elbows so the hands lower down toward back of head and elbows still pointing upward. Exhale to straighten arms. (not shown)

Band is not included.

Start Position



Middle Position



Middle Position



Single Arm Front Overhead Raise



## SE-9

## SEATED EXERCISES

## B A N D

## Seated Band Bent Arm Lateral Raise

## CAUTION

- **Shoulder impingement – reduce range of motion and load**
- Make sure that you are using the bands in a manner that reduces your risk of injury. Wear eye protection such as goggles or glasses while using resistance bands for exercise.

## SPRING POSITION

**ARM RESTS BACK**

**BASE or SIDE CONNECTORS** – Loop band on one side connector.

**LIGHT BAND**

## BODY POSITION

Middle or back of chair.

Feet on ground.

Back upright, neck straight, eyes looking forward.

Arm hangs down by side.

## MOVEMENT

**START** – Raise side arm with slight bend slowly at 45 degrees to the side until ear height or lower.

**END** – Inhale to lower to start position.

## SEQUENCING

6-8 repetitions.

Slow and even speed throughout. (1-2 seconds up and 1-2 seconds down)

As hands go up, feel like you are dropping the shoulders down and wide.

## VARIATIONS

**“Standing”** – This exercise can also be done in the standing position as shown. Use one arm only to press up and down. Add rotation for variation. (as shown)

Band is not included.

Start Position



Middle Position



Standing Bent Arm Lateral Raise



# MY SMARTFIT CHAIR

MY NEW  
REGENERATION of ENERGY

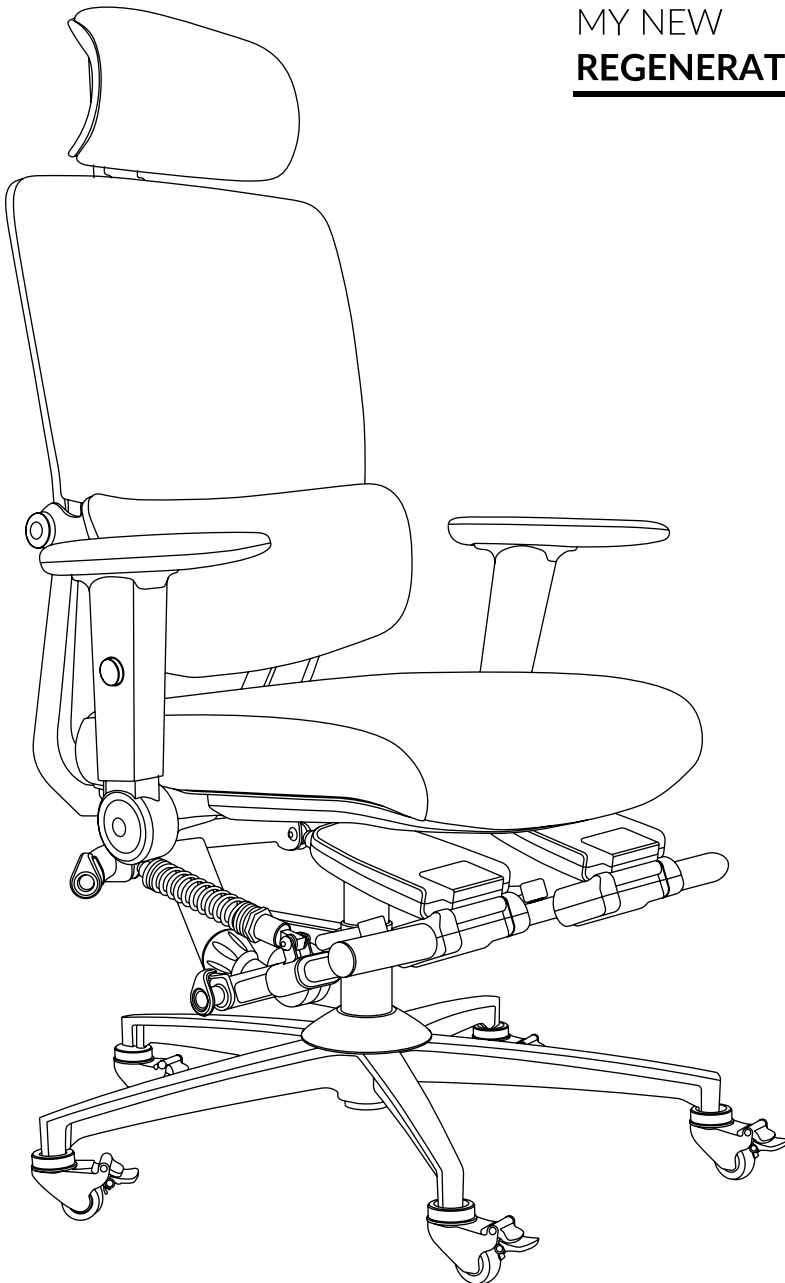

**ST****SECTION 2****STANDING EXERCISES****FOUNDATIONAL***ST-1* Standing Press down Front*ST-2* Standing Press down Side*ST-3* Achilles Stretch*ST-4* Standing Rolldown**INTEGRATED***ST-5* Standing Press down Front (variation)*ST-6* Side-standing*ST-7* Standing Alternating Arm Push Down*ST-8* Standing Alternating Arm Push Down Rotation**BAND***ST-9* Upright Row Series*ST-10* Bicep Curls*ST-11* Ski Squats

# ST-1

## STANDING EXERCISES

### FOUNDATIONAL

## Standing Press Down Front

### SPRING POSITION

**HIGH**

### BODY POSITION

Standing facing "TOWARD" chair.

Tall, looking forward.

Ball of foot (toe end) on the pedal.

### MOVEMENT

**START** - Exhale to press down smoothly until the floor.

**END** - Inhale to control the movement smoothly back to the top.

### SEQUENCING

8-12 repetitions each leg.

Slow and constant speed throughout. (2 seconds down, 2 seconds up)

Keep body perfectly still and upright with only the leg moving up and down.

### VARIATIONS

**"Pumping in the Dark"** - Once in position and after performing the first repetition, close both eyes to continue, thereby challenging balance.

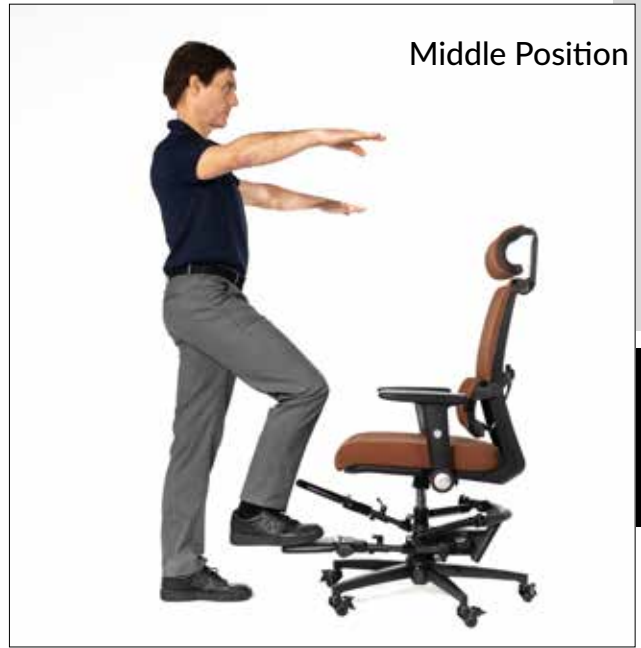

# ST-2

## STANDING EXERCISES

### FOUNDATIONAL

Standing Press Down Side-Arms out to the side at shoulder height

#### SPRING POSITION

**HIGH**

#### BODY POSITION

Standing "SIDEWAYS" in front of chair, behind the pedal center line, about 8-12 inches away from the chair.

Stand tall, looking forward.

Ball of foot (toe end) on the farther pedal at around 45 degrees to the body.

#### MOVEMENT

**START** – Exhale to press down smoothly until the floor using the inner thigh muscles on both legs to squeeze. Foot moves in a slight arc downwards and inwards toward your floor foot's toes.

**END** – Inhale to control the movement smoothly back to the top. Feel like you are opening the hip up and out.

#### SEQUENCING

8-12 repetitions each leg.

Slow and constant speed throughout. (2 seconds down, 2 seconds up)

Keep body perfectly still with only the leg moving up and down.

#### VARIATIONS

**“Pumping in the Dark”** – Once in position and after performing the first repetition, close both eyes to continue, thereby challenging balance.

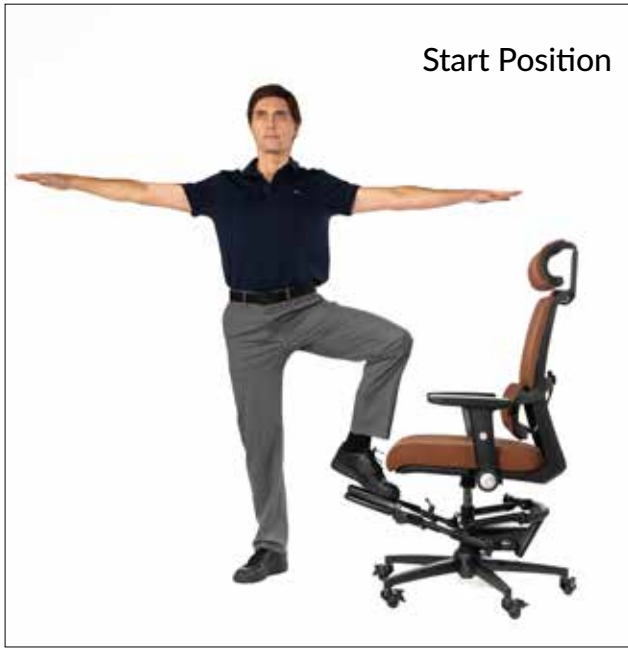

# ST-4

## STANDING EXERCISES

### FOUNDATIONAL

## Standing Rolldown

#### CAUTION

**Lumbar disc herniation**

#### SPRING POSITION

**LOW or HIGH**

#### BODY POSITION

Standing facing "TOWARD" chair, about 12 inches away, feet narrow and parallel.

#### MOVEMENT

**START** - Inhale to stand tall and then exhale and roll the head downward, (chin to chest) through the spine and forward until hands reach the pedals.

**MIDDLE** - Heels of hands on pedals with fingers to the side, pull navel in tightly and continuing smoothly pushing both pedals down toward the ground. (or as far as you can) **DO NOT BOUNCE!**

**END** - Inhale at the bottom, and then exhale and slowly stack yourself back upward until the pedals reach home base. Inhale and repeat 3-5 times before fully stack up to standing.

#### SEQUENCING

3 sets of 3-5 repetitions.

Slow. (5 seconds down, 2 seconds hold, 5 seconds up)

Focus on pulling belly in to support lumbar spine throughout.

Curl the spine like "rolling up a yoga mat."

#### VARIATIONS

**"Flat Back"** - Start in a semi-squat position and keep back straight during the push down by hinging from the hips.

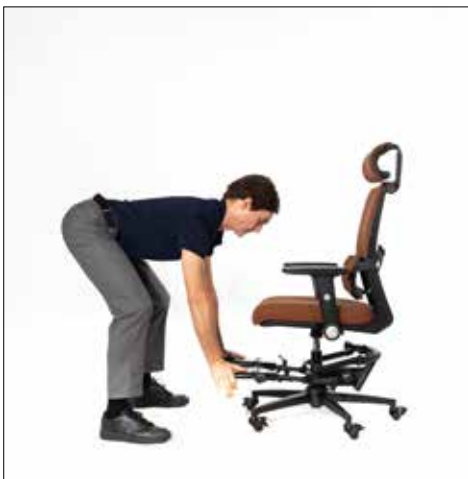
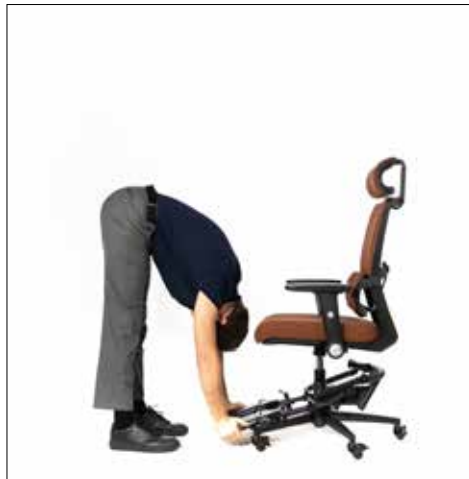
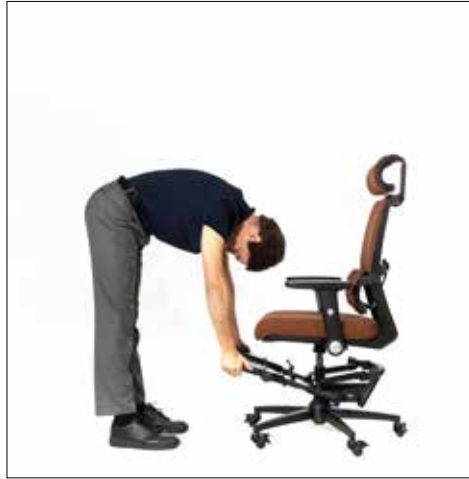

# ST-5

## STANDING EXERCISES

### INTEGRATED

## Standing Press Down Front (variation)

### SPRING POSITION

**HIGH**

### BODY POSITION

As with **ST-1 Standing Press Down Front**.

### MOVEMENT

As above.

### SEQUENCING

As above.

### VARIATIONS

**“Goal post”** – Hands straight up toward ceiling.

**“Reversing Car”** – Hands to side and rotate on press down, turn back to center on knee up phase.

**“Tiptoe”** – Floor foot is on tiptoe (point position) throughout the movement. (not shown)

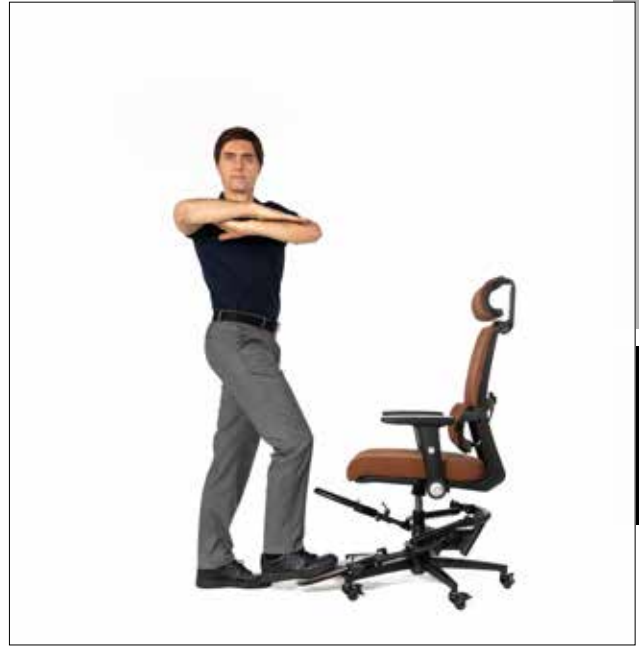
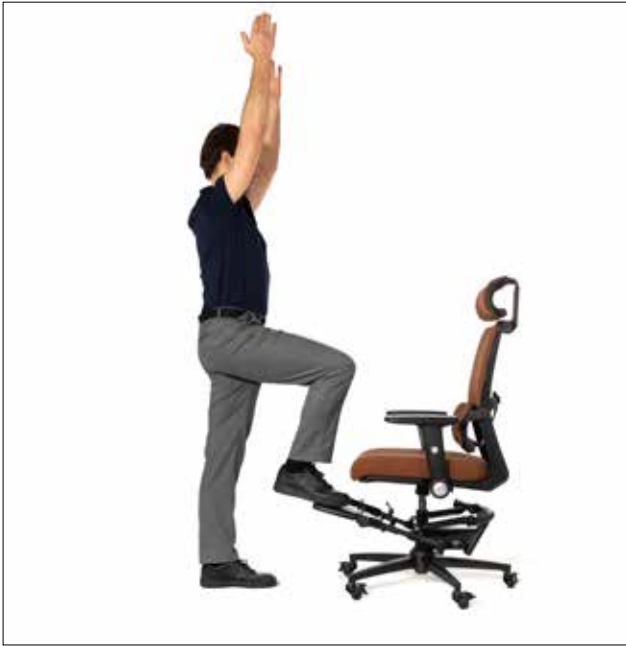

Standing Press Down Front with Spine Twist

# ST-6

## STANDING EXERCISES

INTEGRATED

### Side-standing

**SPRING POSITION**

**HIGH**

**BODY POSITION**

As with **ST-2 Standing Press Down Side**.

**MOVEMENT**

As above.

**SEQUENCING**

As above **but bend to the side as you push the bar down with your foot.**

**VARIATIONS**

**“On Point”** – Support leg stands on tiptoe. (not shown)

**“Reverse Pump”** – Cross the leg over and repeat the same sequence as above and side-standing leg pump.

Mermaid Press Down Side

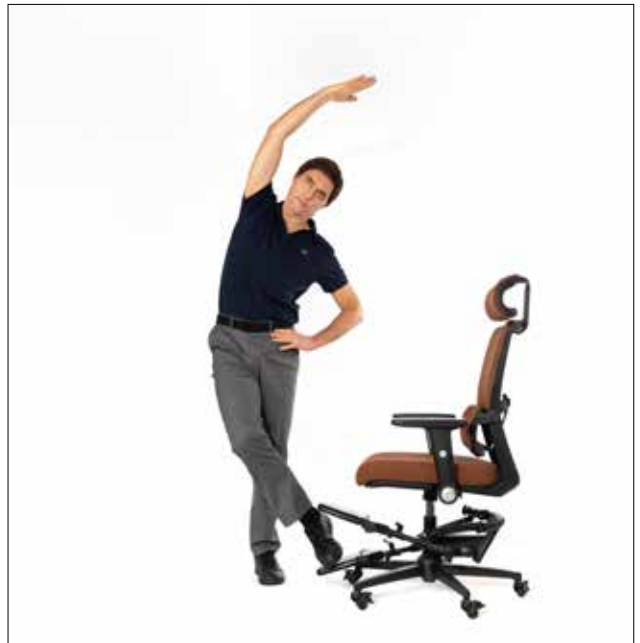
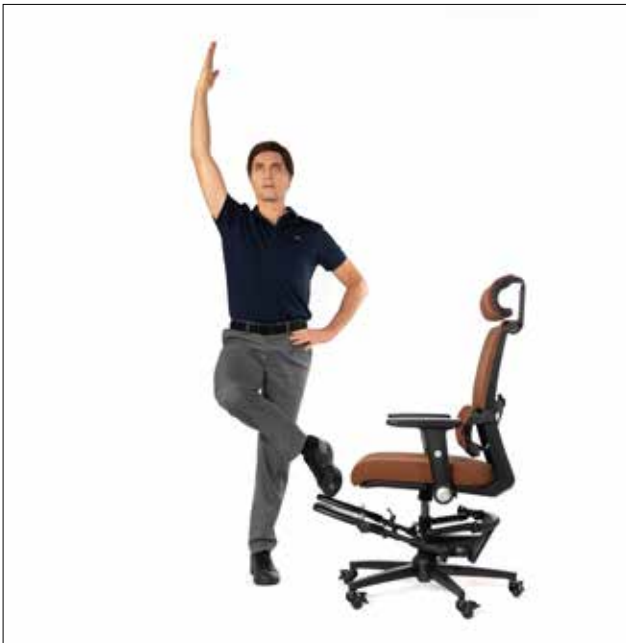
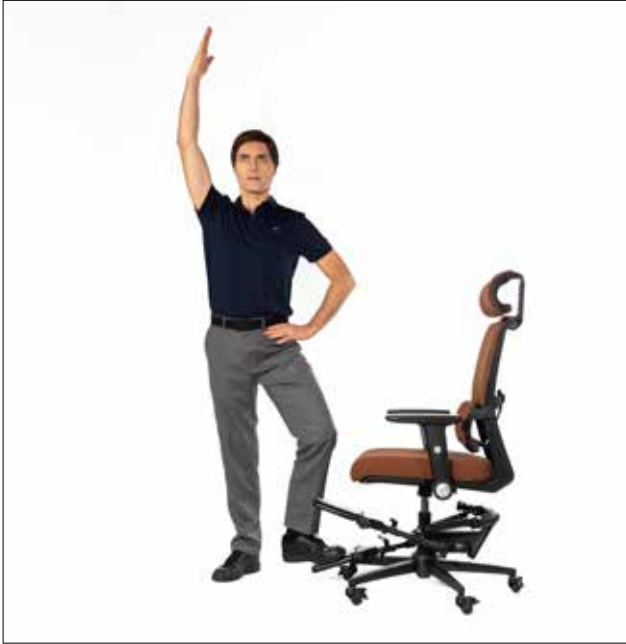

Arms Out to the Side at Shoulder Height  
Press Down Cross Over

Mermaid Press Down Cross Over

# ST-7

## STANDING EXERCISES

INTEGRATED

### Standing Alternating Arm Push Down

**CAUTION**

**Lumbar disc herniation**

**SPRING POSITION**

**LOW or HIGH**

**BODY POSITION**

As with **ST-4 Standing Rolldown**.

**MOVEMENT**

**START** - Inhale to stand tall and then exhale and roll the head downward, (chin to chest) through the spine and forward until hands reach the pedals.

**MIDDLE** - Press one pedal down ¼ way and then the other just past it. Alternate pressing in small "staircase" style until the bottom.

**END** - Walk back "up the stairs" the same way.

**SEQUENCING**

Keep pelvis still and rotate from the upper spine and shoulders.

Arms stay straight at all times.

Knees can bend if limited by hamstring flexibility.

**VARIATIONS**

**“Tricep Walking Pump”** - As with Tricep Pump, but alternating arms up and down. (not shown)

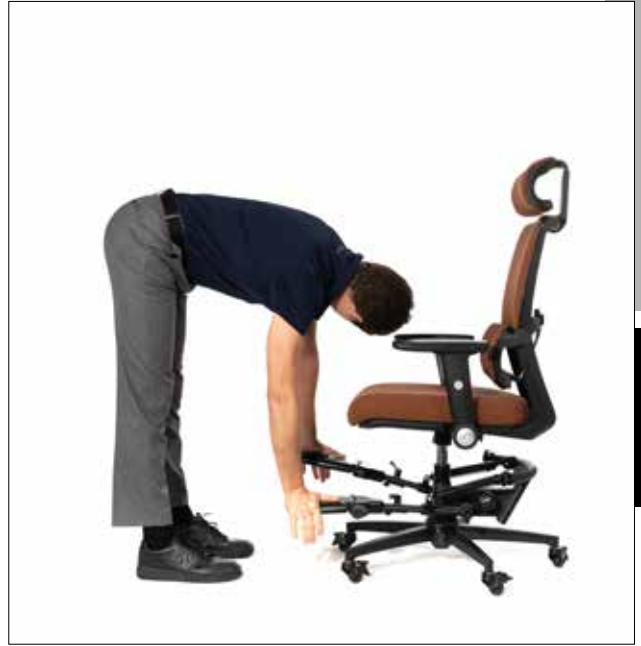
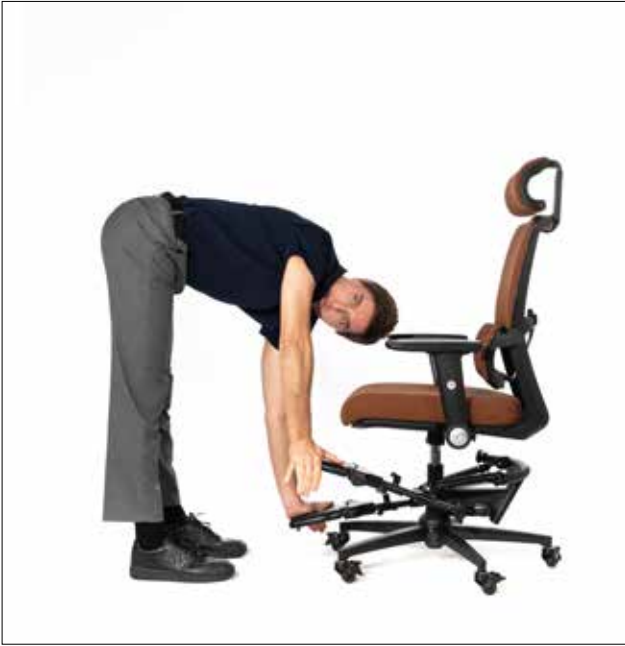

Standing Alternating Arm Push Down



## ST-8

## STANDING EXERCISES

## INTEGRATED

## Standing Alternating Arm Push Down Rotation

## CAUTION

**Lumbar disc herniation**

## SPRING POSITION

**LOW or HIGH**

## BODY POSITION

Standing facing "TOWARD" chair, about 12 inches away, feet narrow, and parallel and slight knee bend.

Hinge forward with straight back and single hand reaches to opposite pedal (Ex. right hand to left pedal). Other arm holds out to the side.

## MOVEMENT

**START** - Keep pelvis facing backwards, as you push the pedal down, rotate the side arm around toward the ceiling. Keep your eyes on that free hand.

**MIDDLE** - Maintain back as straight as possible through, bending the knees slightly if needed. (for tight hamstrings)

**END** - Inhale back up and "de-rotate", bring free arm back to parallel with the ground.

## SEQUENCING

2-3 sets of 3-5 repetitions each side, alternating sides each set.  
Slow. (2-3 seconds down, 2-3 seconds up)

Focus on pulling belly in to support lumbar spine throughout.  
Keep spine as straight as possible, bending knees if needed.

## VARIATIONS

**"Curl and Turn"** - Articulate the spine segmentally throughout the roll. Range of motion will be less in this version, so maintain good core control by moving slowly and with tight belly.

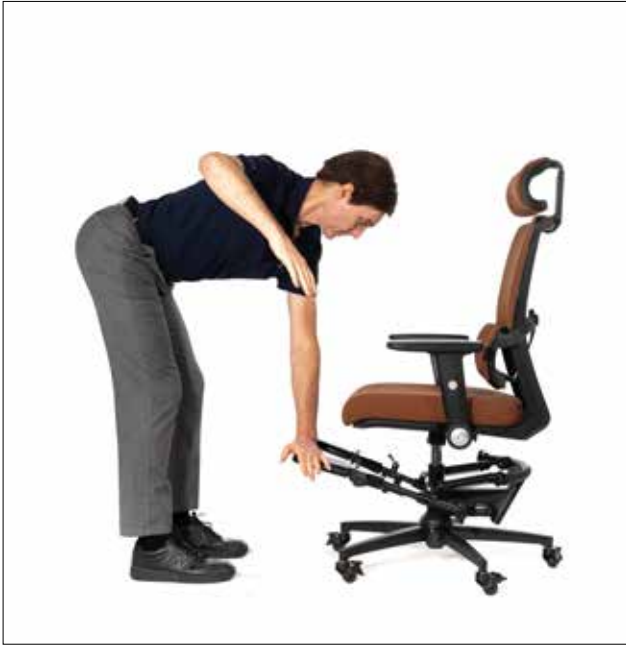

Standing Alternating Arm Push Down Rotation

ST-9

## STANDING EXERCISES

B A N D

## Upright Row Series

## CAUTION

- **Shoulder impingement – reduce range of motion and load**
- Make sure that you are using the bands in a manner that reduces your risk of injury. Wear eye protection such as goggles or glasses while using resistance bands for exercise.

## SPRING POSITION

**ARM RESTS BACK**

**SEAT-SIDE or BASE CONNECTORS** – Loop band on left and right connectors.

**MEDIUM OR LIGHT BAND**

## BODY POSITION

Standing behind and then facing "TOWARD" chair.  
Back upright, neck straight, eyes looking forward.

## MOVEMENT

**START** – Take a single strand of band in both hands at shoulder width apart and palms forward.

**MIDDLE** – Inhale and lift elbows wide and upward in a smooth arc. Hands come toward the chin height.

**END** – Exhale and lower slowly back to start position in front of hips.

## SEQUENCING

8-12 repetitions.

Slow and even speed throughout. (1-2 seconds up and 1-2 seconds down)

Keep shoulders down and away from the ears throughout.

Move further away from chair to increase the tension in the band or move to the "BASE connectors."

## VARIATIONS

**"Circling Rows"** – Arc the arms up and back and down and forward in a slightly circular motion. (not shown)

**"Rotation Rows"** – Rotate through the upright row movement.

Band is not included.

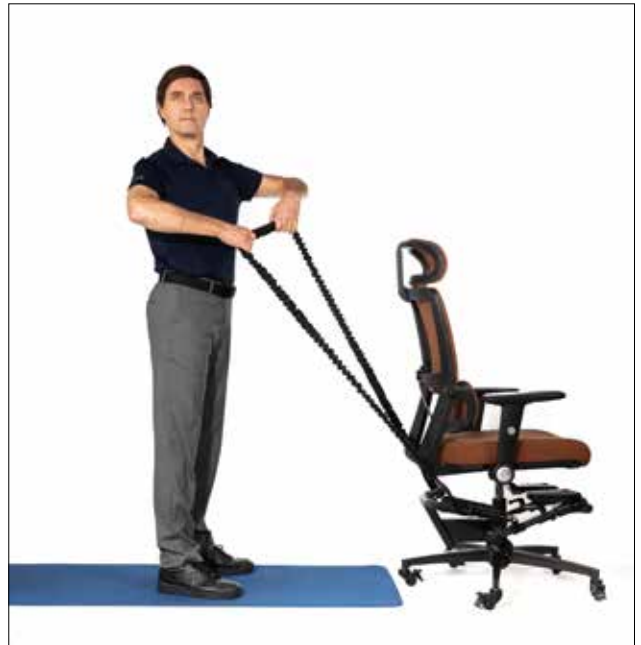

Band Upright Row with Spine Rotation

## ST-10

## STANDING EXERCISES

## BAND

## Bicep Curls

## CAUTION

Make sure that you are using the bands in a manner that reduces your risk of injury. Wear eye protection such as goggles or glasses while using resistance bands for exercise.

BAND  
POSITION &  
STRENGTH**ARM RESTS BACK**

**BASE CONNECTORS** – Loop band on both BASE connectors.

**MEDIUM OR LIGHT BAND**

## BODY POSITION

Standing or Seated facing "TOWARD chair."

Arms straight down and forward, palms facing forward.

## MOVEMENT

**START** – Take single band in both hands at shoulder width apart and palms forward.

**MIDDLE** – Exhale and fold at elbows to pull hands upward in a smooth arc toward the shoulders.

**END** – Inhale and lower slowly back to start position.

## SEQUENCING

8-12 repetitions.

Slow and even speed throughout. (1-2 seconds up and 1-2 seconds down)

As hands go up, feel like you are dropping the shoulders down and wide.

## VARIATIONS

**“Rotation”** – Add a rotation during the curl.

**“Wide Grip”** – As you curl the hands upwards, also go wider with the hands while keeping the elbows at the same position. (not shown)

Band is not included.

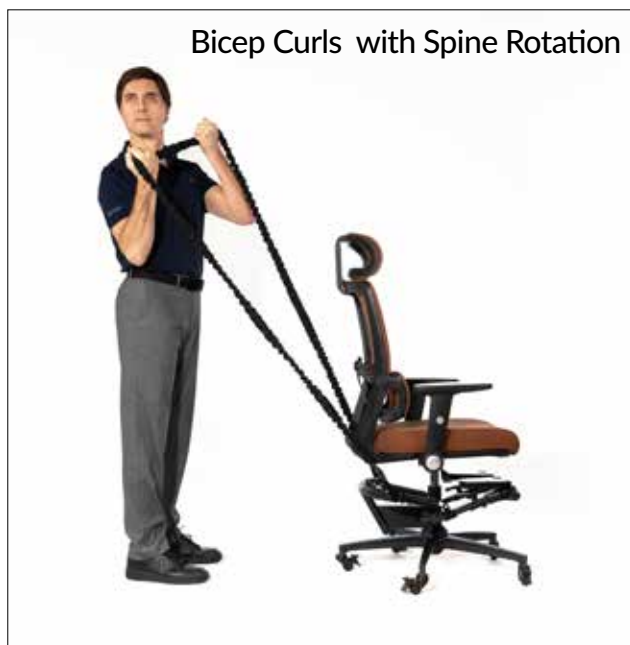
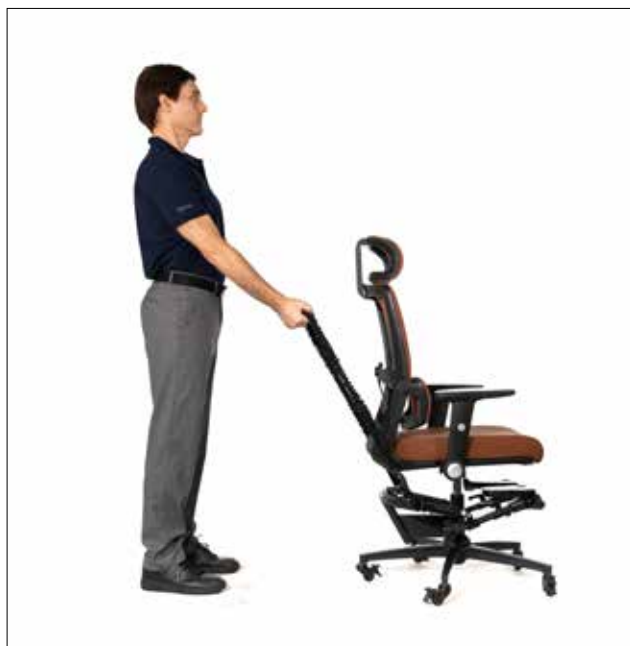

Seated Float on the Floor Bicep Curls



## ST-11

## STANDING EXERCISES

## BAND

## Ski Squats

## CAUTION

Make sure that you are using the bands in a manner that reduces your risk of injury. Wear eye protection such as goggles or glasses while using resistance bands for exercise.

BAND  
POSITION &  
STRENGTH**ARM RESTS BACK**

**BASE CONNECTORS** – Loop band on both "BASE connectors."

**MEDIUM BAND (or HEAVY BAND if you have)**

## BODY POSITION

Stand 3-4 feet away and facing "TOWARD chair."

Hold band in the biceps curl position in front of shoulders/chest.

## MOVEMENT

**START** – Imagine you are sitting back on a low stool. Aim to keep the spine perpendicular to the ground as you sit.

**MIDDLE** – Depending on strength and knee health, you can go down to thighs parallel to the floor.

**END** – Press through the outside of the heels and little toe to come back up. This will activate glutes more and support knee function.

## SEQUENCING

10-15 repetitions.

Slow and even speed throughout. (2-3 seconds down and 2-3 seconds up)

As hands go up, feel like you are dropping the shoulders down and wide.

## VARIATIONS

**"Balance Squat"** – In either forward or reverse position, (below) lift one leg into "karate kid" position. Balance there for 10 seconds. Challenge by slightly bending the knee into a  $\frac{1}{4}$  squat.

**"Pistol Squat" (Advanced)**– Lift one foot away from the ground and do the full depth ski squat with one leg only.

Band is not included.

Banded Squats

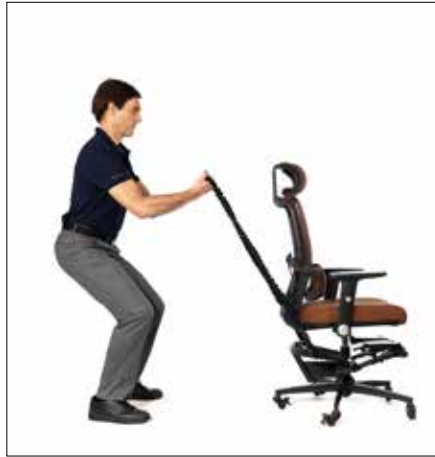

Banded Single Leg Squat



# MY SMARTFIT CHAIR

MY NEW  
REGENERATION of ENERGY

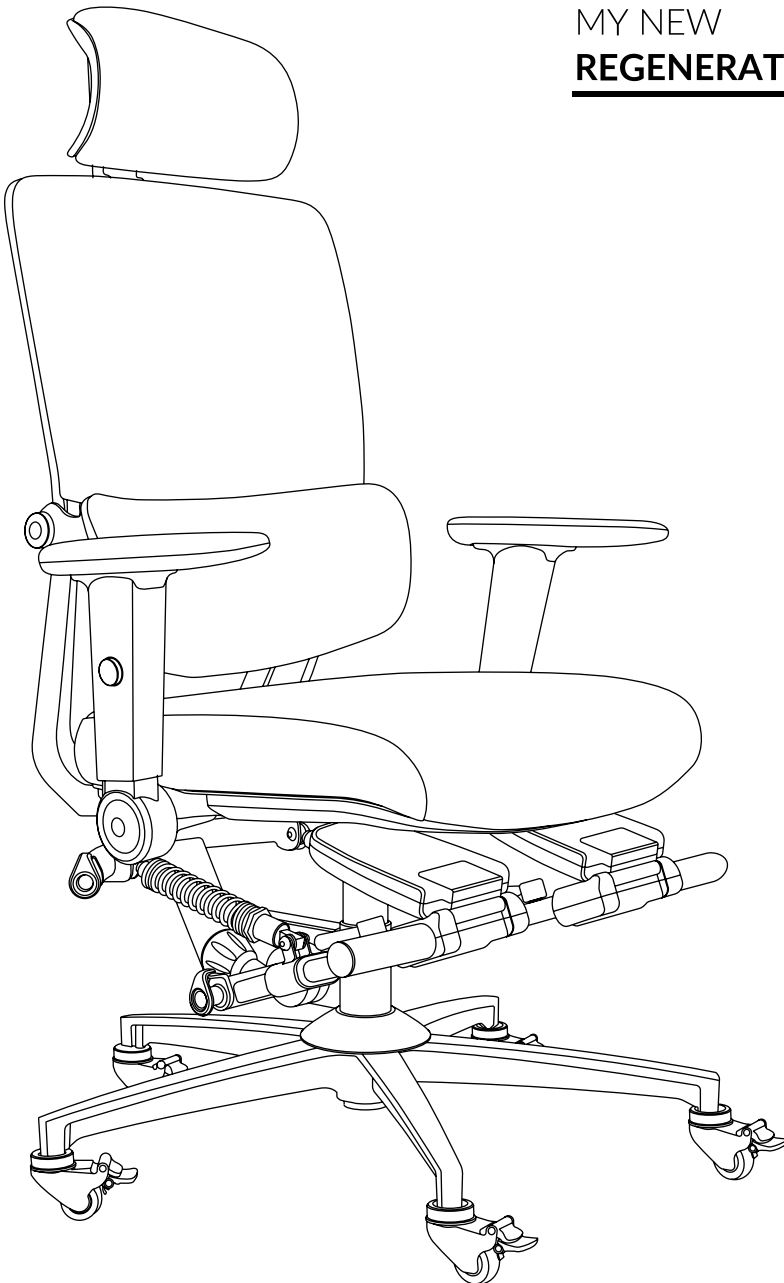

**KN****SECTION 3****KNEELING EXERCISES****FOUNDATIONAL***KN-1* Kneeling Rolldown*KN-2* Kneeling Side Bend**INTEGRATED***KN-3* Kneeling Alternating Arm Push Down*KN-4* Rolldown Rotation*KN-5* Kneeling Mermaid to Front Wave**BAND***KN-6* Donkey Kicks*KN-7* Standing Lateral Leg Raises*KN-8* Rear Straight Leg Raises*KN-9* High Knee March

## KN-1

## KNEELING EXERCISES

## FOUNDATIONAL

## Kneeling Rolldown

## SPRING POSITION

**LOW** or **HIGH**

## BODY POSITION

Mat under knees, kneeling on ground facing "TOWARD chair."

Hands on pedals, fingers facing outward.

Back upright, neck straight, eyes looking forward.

## MOVEMENT

**START** - Exhale and curl the chin toward the chest and roll the spine down, pushing the pedals downward. Keep the pelvis above the knees. (do not hinge back)

**MIDDLE** - The lowest point is where you feel the body is going to fall forward. Aim for maximum curvature in the spine. You may or may not reach the floor - that is not the goal.

**END** - Breathe in, pull in the belly, and uncurl the body back to a full kneeling position.

## SEQUENCING

8-10 repetitions.

Slow and even speed throughout. (2-4 seconds down and 2-4 seconds up)

Focus on the curling of the thoracic spine. (like an angry cat)

Thighs stay vertical throughout. Keep pelvis above knees at all times.

## VARIATIONS

See integrated movements below.

Mat is not included.

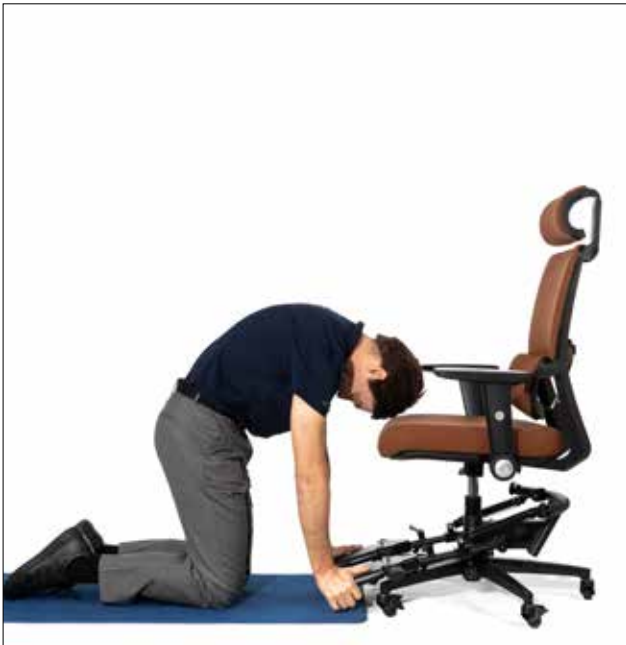
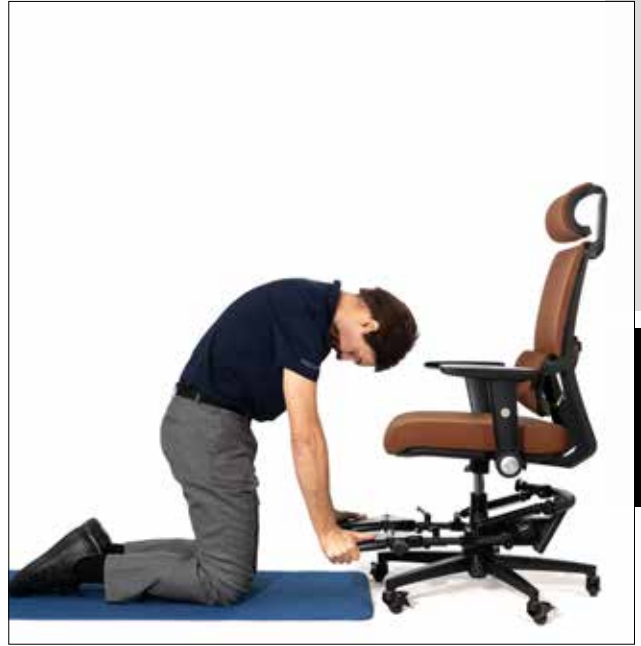
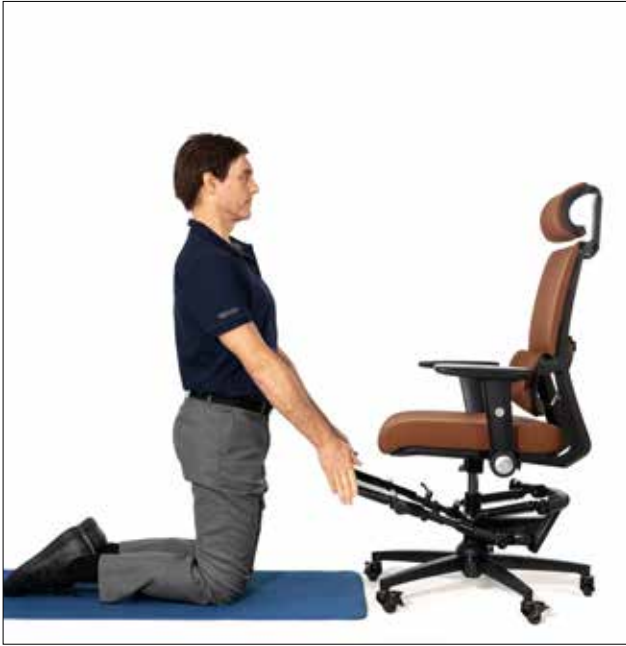

## KN-2

## KNEELING EXERCISES

## FOUNDATIONAL

## Kneeling Side Bend

## SPRING POSITION

**HIGH, single pedal**

## BODY POSITION

Mat under knees, kneeling on ground facing "SIDEWAYS."  
One hand on pedal, other hand out to side or behind head.  
Back upright, neck straight, eyes looking forward.

## MOVEMENT

**START** - Inhale and press down through pedal and arc other arm up and over the head toward the ceiling. (moving in the side plane)

**MIDDLE** - The lowest point is where you feel the outside knee starting to lift away from the ground. Anchor it solidly.

**END** - Breathe in at the bottom, then exhale while you pull in the belly and uncurl the body back to a full kneeling position.

## SEQUENCING

6-8 repetitions each side.

Slow and even speed throughout. (2-4 seconds down and 2-4 seconds up)

Imagine you are turning a wheel in the middle of your chest. (rotating to the side)

Thighs stay vertical throughout. Keep pelvis above knees at all times.

## VARIATIONS

See integrated movements below.

Mat is not included.

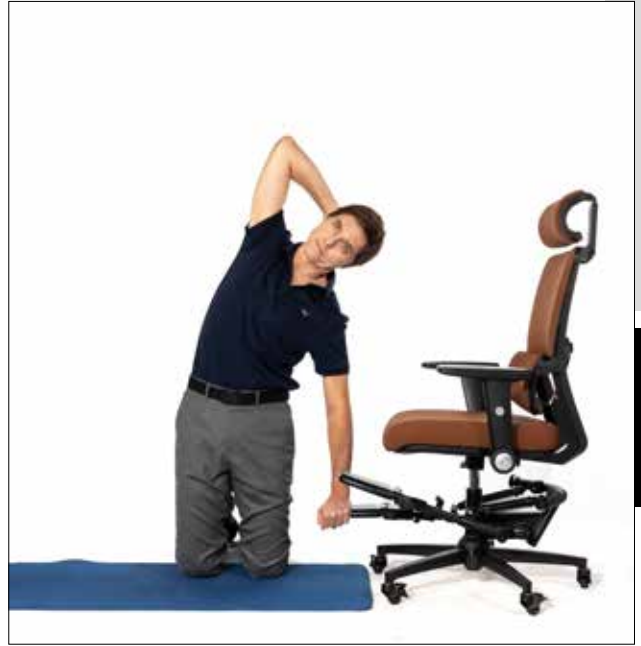

## KN-3

## KNEELING EXERCISES

INTEGRATED

## Kneeling Alternating Arm Push Down

## SPRING POSITION

LOW or HIGH

## BODY POSITION

As above for **KN-1 Kneeling Rolldown**.

## MOVEMENT

**START** - Alternating left/right hand pushing down, down, down, and then up, up, up.

Keep both arms straight and rotate the shoulders to move the pedal.

## SEQUENCING

5-6 repetitions each arm.

As above for Kneeling Rolldown.

Eyes and head turn left to right with each hand. (look and turn to the high hand side)

Mat is not included.

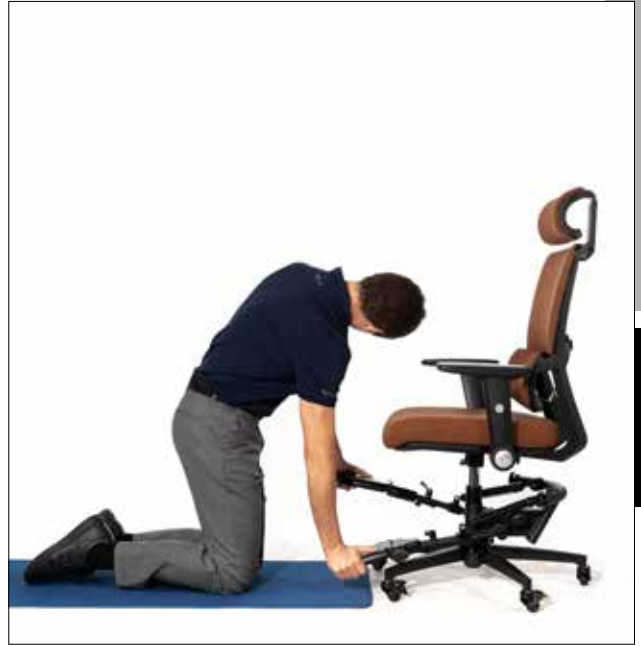
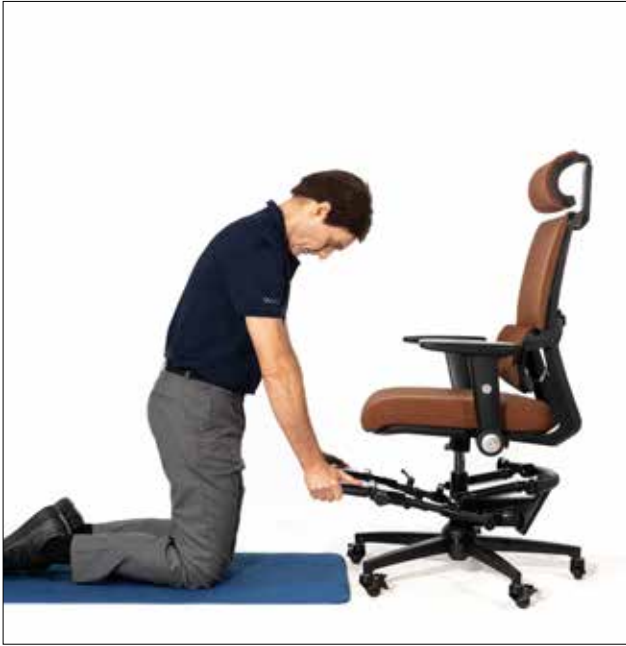

Kneeling Alternating Arm Push Down

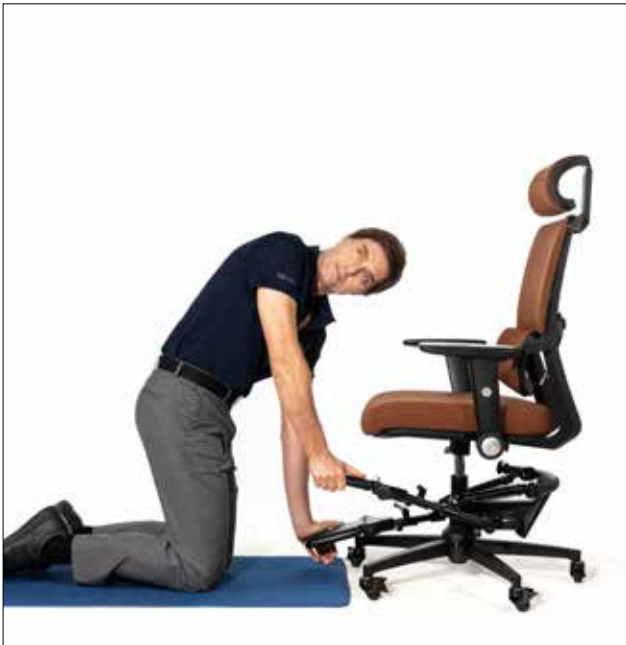

## KN-4

## KNEELING EXERCISES

## INTEGRATED

## Rolldown Rotation

## SPRING POSITION

LOW or HIGH

## BODY POSITION

As above for **KN-1 Kneeling Rolldown**.

## MOVEMENT

**START** - Place one hand on the opposite pedal and other arm straight out to the side.

**MIDDLE** - Hinge pelvis back slightly and keep spine straight as you rotate the side arm around and toward the ceiling while pushing the pedal down.

**END** - De-rotate to stack back up.

## SEQUENCING

5-6 repetitions each arm.

Eyes and head turn to focus on the high hand side.

## VARIATIONS

**“Flossing”** - Stay 2/3 of the way down through the movement and then flex and curl the spine like a cat. This will help mobilize mid thoracic vertebra.

Mat is not included.

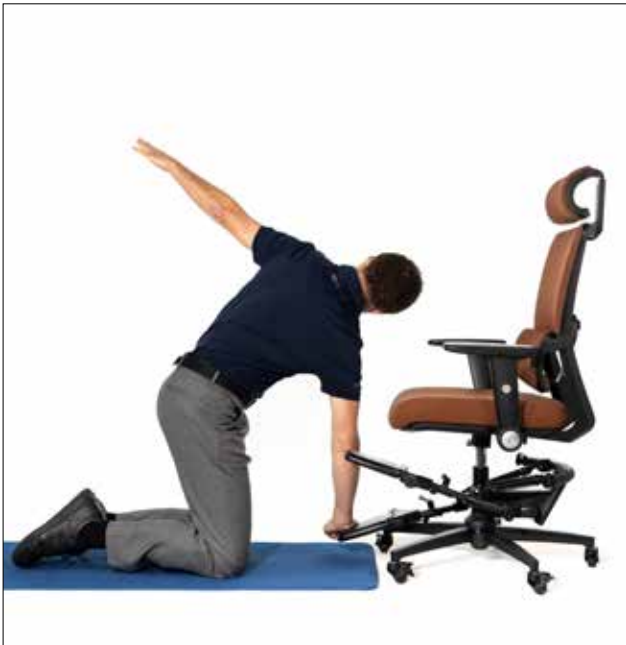
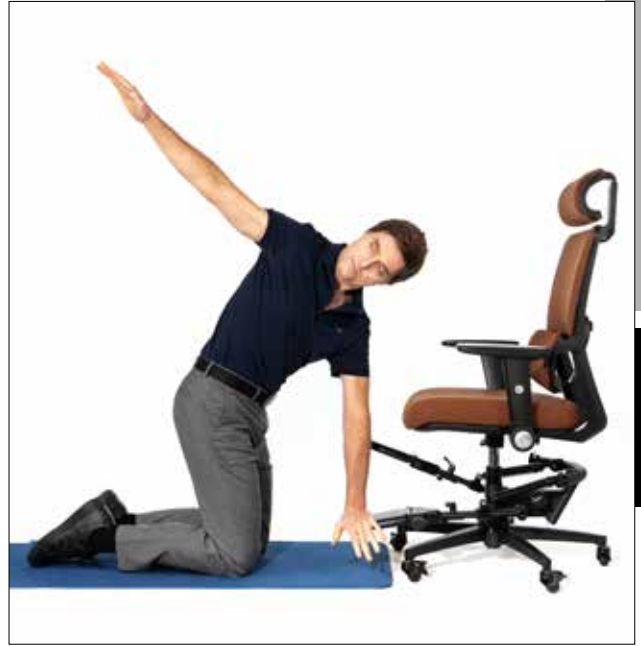
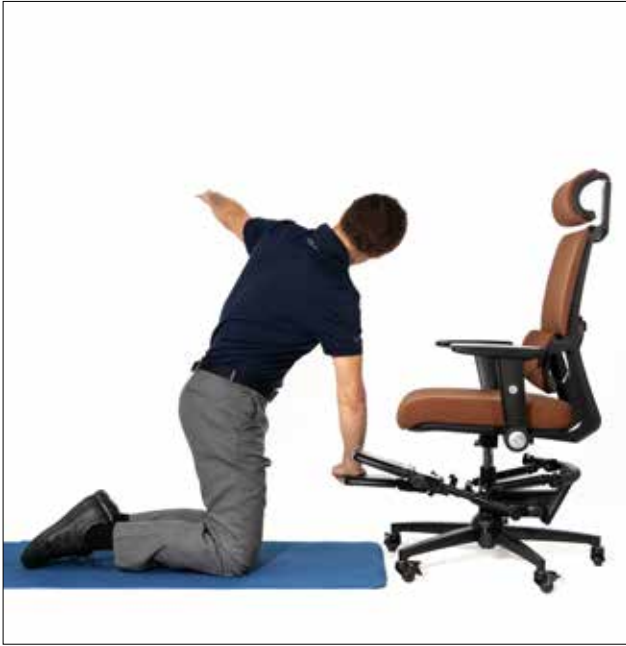

Kneeling Alternating Arm Push Down with Rotation

## KN-5

## KNEELING EXERCISES

## INTEGRATED

## Kneeling Mermaid to Front Wave

## SPRING POSITION

**HIGH, single pedal**

## BODY POSITION

As above for **KN-2 Kneeling Side Bend**.

## MOVEMENT

**START** - As with **Kneeling Side Bend**.

**MIDDLE** -At the lowest point, then rotate the shoulders and weave the side arm down and toward the pedal arm. Turn elbows wide as though hugging someone.

**END** - Breathe in at the bottom, then exhale while de-rotate the body back to a full side kneeling position.

## SEQUENCING

3-5 repetitions each side.

Slow and even speed throughout. (2-4 seconds down and 2-4 seconds up)

Thighs stay vertical throughout. Keep pelvis above knees at all times.

## VARIATIONS

**“Breathing”** - Stay in the weaving position and use 3-4 deep breaths to open and close the back of the rib cage. This will help release back tension.

Mat is not included.



Kneeling Mermaid to Front Wave



KN-6

## STANDING EXERCISES

B A N D

## Donkey Kicks

## CAUTION

Make sure that you are using the bands in a manner that reduces your risk of injury. Wear eye protection such as goggles or glasses while using resistance bands for exercise.

BAND  
POSITION &  
STRENGTH

**BASE CONNECTORS** – Loop band on left and right connectors.  
**MEDIUM BAND**

## BODY POSITION

Standing 3' behind chair, facing "TOWARD" the chair. "HOLD CHAIR" for safety.

One foot loops band around sole/arch, knee bent to 90 degrees.

Single leg standing, leaning forward, holding top outside of chair with bent arms.

Back straight, eyes looking at seat top.

## MOVEMENT

**START** – Exhale and slowly kick leg backwards at 45-degree angle until knee straightens.

**END** – Inhale to return to starting position.

## SEQUENCING

10-12 repetitions each leg.

Slow and even speed throughout. (2 seconds out, 2 seconds back)

Keep support leg straight, but "soft knee." (not locked rigid)

## VARIATIONS

**"Single Arm Runner"** – With the same arm as the band foot, as you kick back, reach the arm forward in line with your ear. (mimicking running) (not shown)

Band is not included.

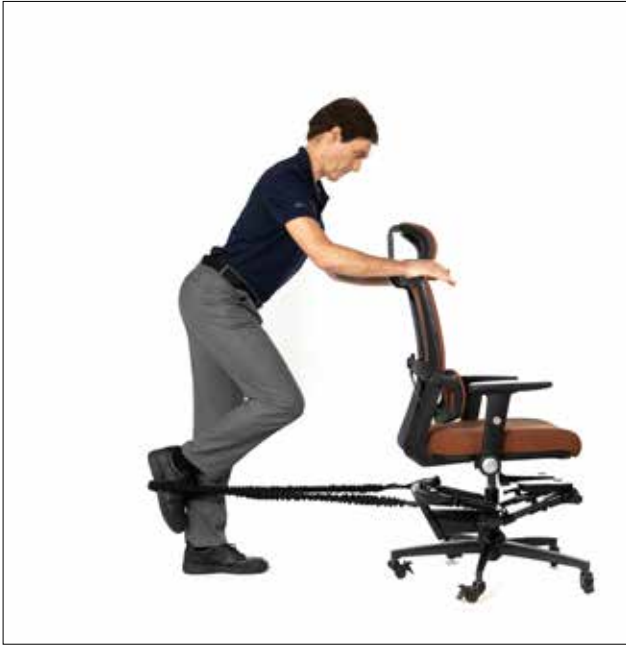

Standing Donkey Kicks



KN-7

## STANDING EXERCISES

B A N D

## Standing Lateral Leg Raises

## CAUTION

Make sure that you are using the bands in a manner that reduces your risk of injury. Wear eye protection such as goggles or glasses while using resistance bands for exercise.

BAND  
POSITION &  
STRENGTH

**BASE CONNECTORS** – Loop band on left and right connectors.  
**MEDIUM BAND**

## BODY POSITION

Standing 3' behind chair, facing "SIDEWAYS."

Loop the band around the ankle of outside foot. (band is in front of support leg) Keep leg moving leg slightly bent at knee.

Reach out arm and balance on top of chair.

Body upright, looking forward with bent arms.

Back straight, eyes looking at seat top.

## MOVEMENT

**START** – Inhale and lift leg out to the side.

**END** – Inhale to return to starting position.

## SEQUENCING

10-12 repetitions each leg.

Movement is quite small. Avoid turning the foot out. Keep foot parallel to ground.

Slow and even speed throughout. (2 seconds out, 2 seconds back)

Control the movement with a squeeze-hold in the outermost position.

## VARIATIONS

**"Sidekick"** – Bend the support leg into a semi squat. Slow press out and in like a karate sidekick.

Band is not included.

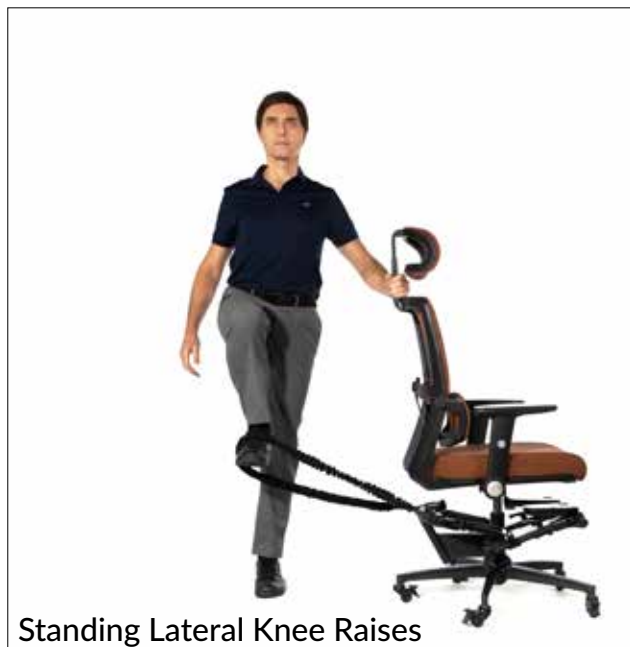

Standing Lateral Knee Raises



KN-8

## STANDING EXERCISES

B A N D

## Rear Straight Leg Raises

## CAUTION

Make sure that you are using the bands in a manner that reduces your risk of injury. Wear eye protection such as goggles or glasses while using resistance bands for exercise.

BAND  
POSITION &  
STRENGTH

**BASE CONNECTORS** - Loop band on left and right connectors.  
**MEDIUM BAND**

## BODY POSITION

Standing 3' behind chair, facing "TOWARD" the chair.  
Loop the band around the ankle of one foot. Keep leg straight.  
Single leg standing, leaning forward slightly, holding top outside of chair with straight arms.  
Back straight, eyes looking forward.

## MOVEMENT

**START** - Exhale and slowly extend straight leg backwards and upwards until body starts to bend forward.  
**END** - Inhale to return to starting position.

## SEQUENCING

10-12 repetitions each leg.  
Hip extension is typically only 10-20 degree behind the torso angle. Avoid arching the lower back. Movement is quite small.  
Slow and even speed throughout. (2 seconds out, 2 seconds back)  
Keep support leg straight, but "soft knee." (not locked rigid)

Band is not included.

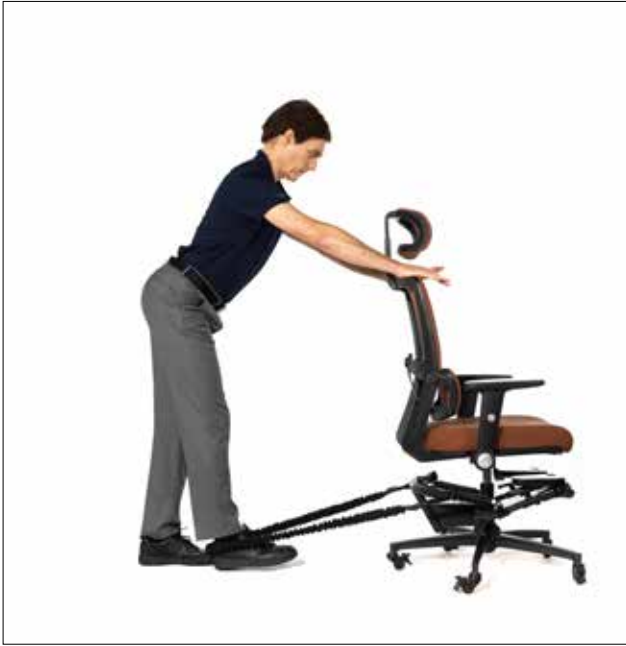

KN-9

## STANDING EXERCISES

B A N D

## High Knee March

## CAUTION

Make sure that you are using the bands in a manner that reduces your risk of injury. Wear eye protection such as goggles or glasses while using resistance bands for exercise.

BAND  
POSITION &  
STRENGTH

**BASE CONNECTORS** – Loop band on left and right connectors.  
**MEDIUM BAND**

## BODY POSITION

Standing 2' behind chair, facing "AWAY, SIDE (below), or FRONT."  
Loop band around the ankle of one foot.  
Reach back one (or two) arms to hold sides/top and stabilize chair.

## MOVEMENT

**START** – Inhale and bend knee forward and upward into a high-march position, aiming for 90-degrees at the knee and hip.  
**END** – Exhale to return to ground.

## SEQUENCING

6-10 repetitions each leg.  
Slow and even speed throughout. (2 seconds out, 2 seconds back)  
Keep support leg straight, but "soft knee." (not locked rigid)

## VARIATIONS

**"Balance March"** – If chair is stable or with someone's help to stabilize chair, bring both arms to side or in front and perform the action.

Band is not included.

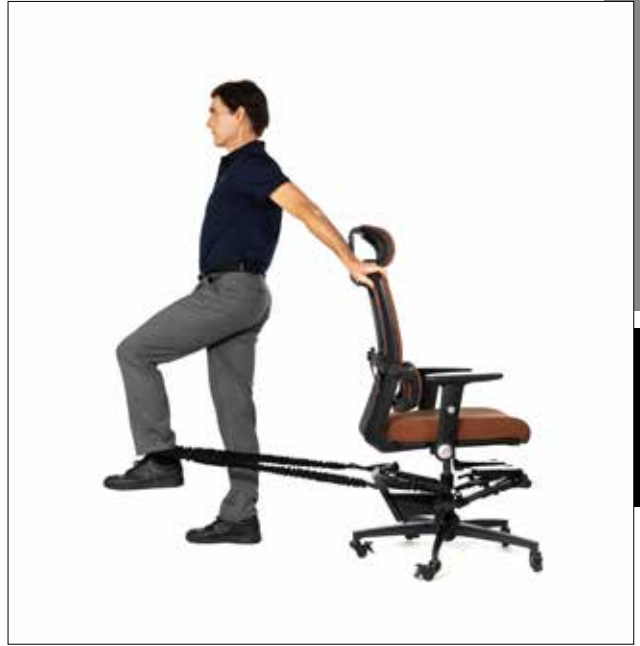

# MY SMARTFIT CHAIR

MY NEW  
REGENERATION of ENERGY

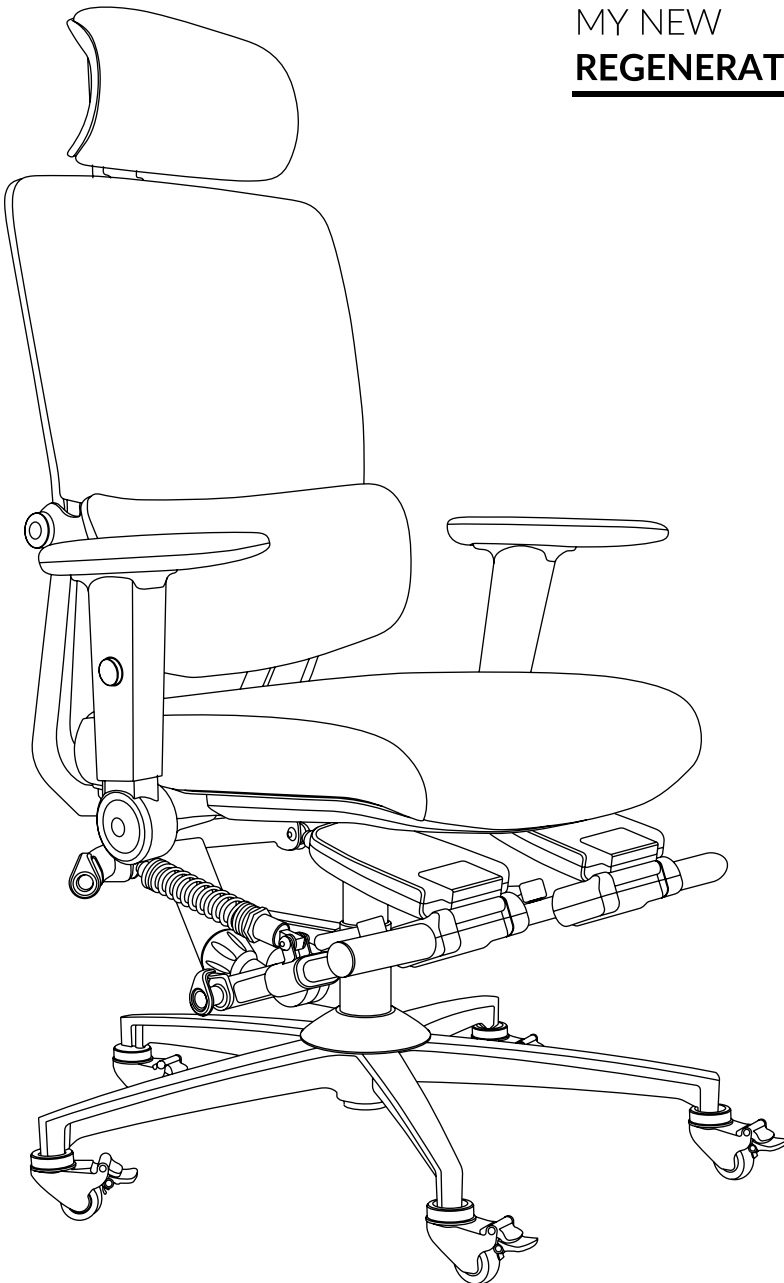

**FL**

## SECTION 4

# FLOOR EXERCISES

### FOUNDATIONAL

- |             |                                   |
|-------------|-----------------------------------|
| <i>FL-1</i> | Spine Stretch Forward             |
| <i>FL-2</i> | Wide-legged Spine Stretch Forward |
| <i>FL-3</i> | Long Back Arms                    |
| <i>FL-4</i> | Swimmer                           |

### INTEGRATED

- |             |                                   |
|-------------|-----------------------------------|
| <i>FL-5</i> | Wide-legged Alternating Arm Twist |
| <i>FL-6</i> | Advanced Swimmer                  |

### BAND

- |              |   |
|--------------|---|
| <i>FL-7</i>  | Full Body Roll Down                     |
| <i>FL-8</i>  | Resistance Band Full Body Roll Up       |
| <i>FL-9</i>  | Resistance Band Rear Delt Row           |
| <i>FL-10</i> | Resistance Band Chest & Over head Press |
| <i>FL-11</i> | Kneeling Side Bend                      |

# FL-1

## FLOOR EXERCISES

### FOUNDATIONAL

## Spine Stretch Forward

#### CAUTION

**Lumbar disc herniation**

#### SPRING POSITION

**LOW**

**MAT ON FLOOR**

#### BODY POSITION

Sit on mat facing "TOWARD" the pedals with straight legs in slight V just wider than pedals.

-If you are flexible, move backwards until you can perform a full stretch.

-If you are less flexible, open legs to a wider V and move closer to pedals.

-You may also choose to sit on a small block about 3-5" high.

#### MOVEMENT

**START** - Exhale and reach forward until both hands are resting on the pedals.

**MIDDLE** - Inhale to prepare, then exhale and press pedals downwards.

**END** - Inhale to return pedals to top and repeat downward press.

#### SEQUENCING

6-12 repetitions.

Slow and even speed throughout. (4 seconds down, 2-4 seconds up)

Aim to use the abdominal muscles to press and lift the pedals.

May bend knees slightly if above positions are unachievable.

#### VARIATIONS

**"Long Sit Walking"** - Alternate the pressing for left to right hands. Keep eyes looking at knees.

Mat is not included.



Spine Stretch Forward Alternating Arms

# FL-2

## FLOOR EXERCISES

### FOUNDATIONAL

## Wide-legged Spine Stretch Forward

#### CAUTION

**Lumbar disc herniation**

#### SPRING POSITION

**LOW  
MAT ON FLOOR**

#### BODY POSITION

As for FL-1 Spine Stretch Forward, open the legs as wide as possible in the V position.

Position body as far away from chair as you can still bend forward and reach the pedals with straight arms.

#### MOVEMENT

**START** - Exhale and reach forward until both hands are resting on the pedals.

**MIDDLE** - Inhale to prepare, then exhale and press pedals downwards.

**END** - Inhale to return pedals to top and repeat downward press.

#### SEQUENCING

6-12 repetitions.

Slow and even speed throughout. (4 seconds down, 2-4 seconds up)

Aim to use the abdominal muscles to press and lift the pedals.

May bend knees slightly or sit on blocks if above positions are unachievable.

#### VARIATIONS

**“Straight-back”** - As above but maintaining a straight back throughout.

**“V Sit Walking”** - Alternate the pressing for left to right hands. Keep eyes looking at knees. (not shown)

**Mat is not included.**

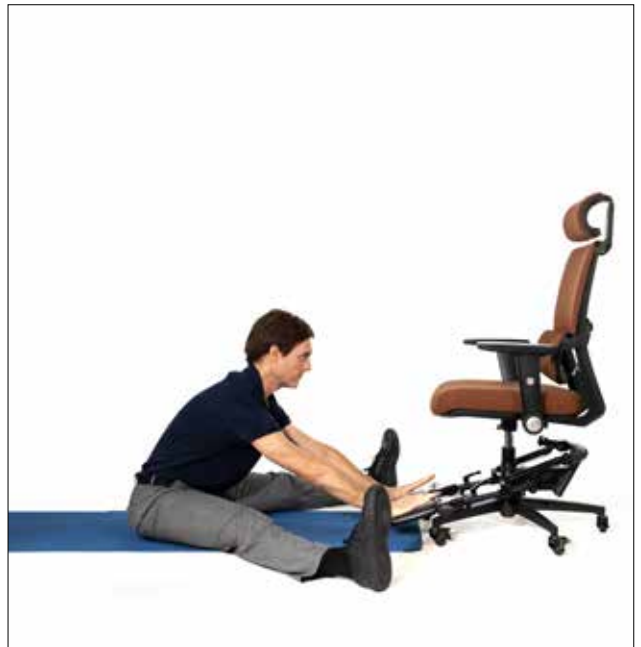
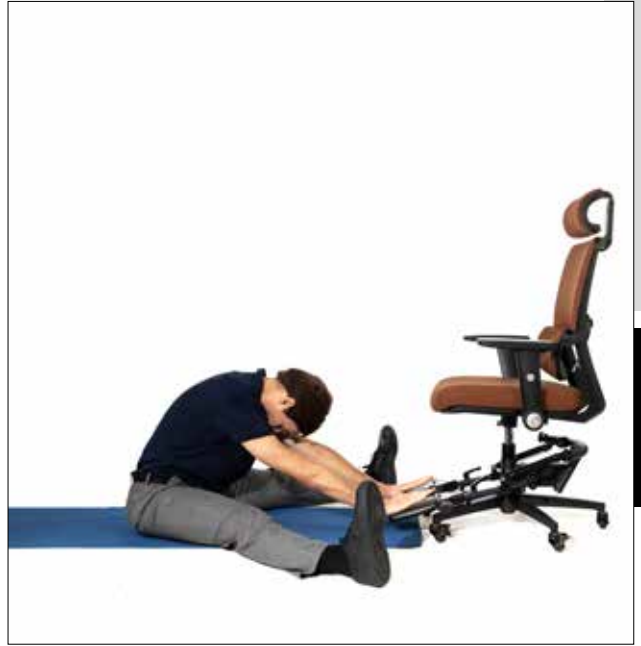
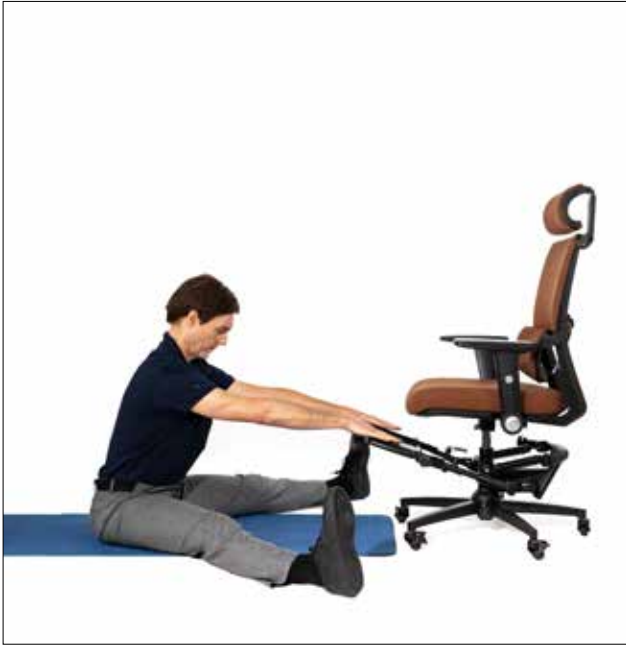

# FL-3

## FLOOR EXERCISES

### FOUNDATIONAL

## Long Back Arms

#### CAUTION

**Shoulder issues (anterior dislocation, impingement, capsulitis)**

#### SPRING POSITION

**LOW OR HIGH  
MAT ON FLOOR**

#### BODY POSITION

Sitting on floor facing "AWAY" from pedals.

Legs straight or crossed in front of you.

Bend elbows and reach hands behind to place heels of hands on pedals, fingers facing forwards or turned outwards.

Keep back upright and straight as possible. May need to sit on block.

#### MOVEMENT

**START** - Exhale to press the pedals down to ground.

**END** - Inhale to return pedals to top and repeat downward press.

#### SEQUENCING

6-12 repetitions.

Slow and even speed throughout. (4 seconds down, 2-4 seconds up)

Aim to use the armpit area muscles to press and lift the pedals.

Keep shoulders down away from ears. (avoid shrugging)

#### VARIATIONS

**"Alternate Reverse Dips"** - Press one arm down at a time. Slightly rotate head and shoulder toward the downward arm side.

Mat is not included.

### Long Back Arms

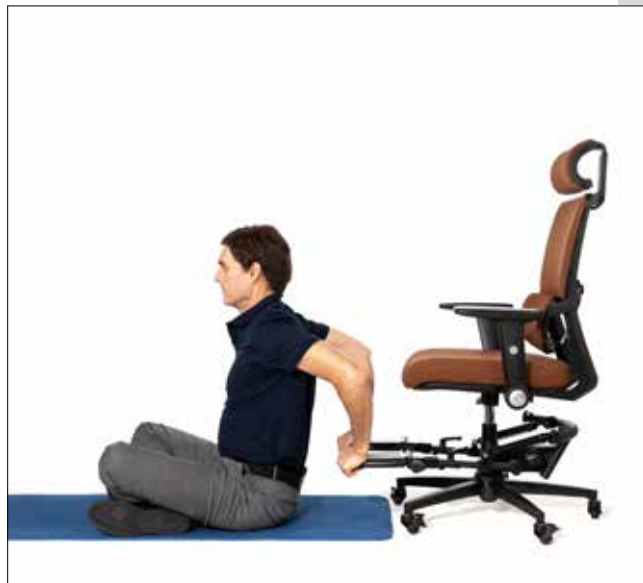
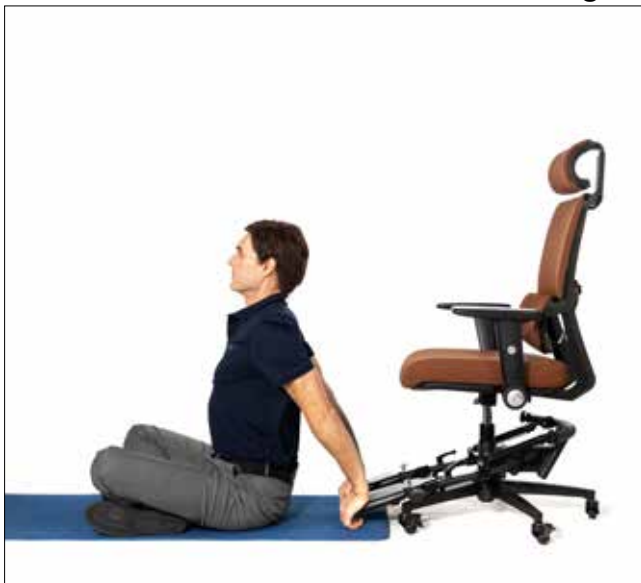

### Long Back Arms with Spine Rotation



### Alternating Long Back Arms with Rotation

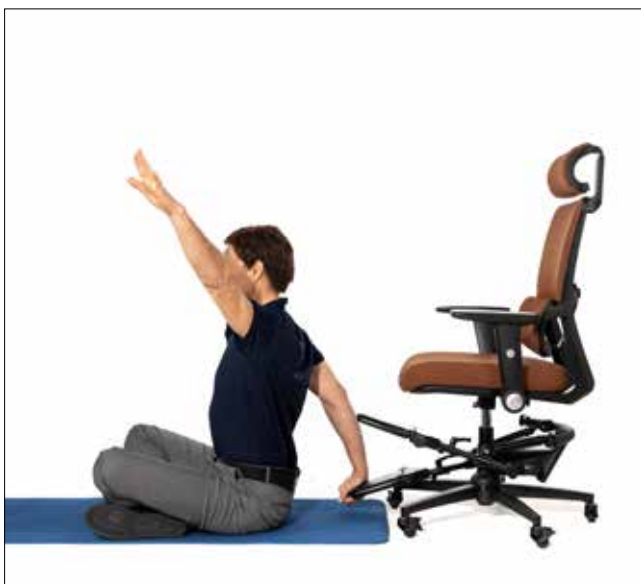

# FL-4

## FLOOR EXERCISES

### FOUNDATIONAL

### Swimmer

#### CAUTION

**Shoulder issues (posterior dislocation, impingement, capsulitis)**

#### SPRING POSITION

**LOW OR HIGH  
MAT ON FLOOR**

#### BODY POSITION

Lie face down, facing the pedals. When arms are outstretched, you should be able to reach the pedals.

Keep chin tucked in and look down at the mat.

#### MOVEMENT

**START** - Lift head and chest away from ground and reach the pedals one hand at a time until both are on each pedal.

**MIDDLE** - Exhale and smoothly press the pedals down to the ground, keeping arms as straight as possible.

**END** - Inhale to return pedals to top and repeat downward press.

#### SEQUENCING

8-12 repetitions.

Start slowly and buildup speed. Only arms and legs move. Body stay still.

Aim to use the armpit area muscles to press and lift the pedals.

Keep shoulders down away from ears. (avoid shrugging)

#### VARIATIONS

**“Alternate Swimmer”** - Press one arm down at a time. Slightly rotate head and shoulder toward the downward arm side.

Mat is not included.



# FL-5

## FLOOR EXERCISES

### INTEGRATED

## Wide-legged Alternating Arm Twist

### CAUTION

**Lumbar disc herniation**

### SPRING POSITION

**LOW  
MAT ON FLOOR**

### BODY POSITION

As for **FL-1 Spine Stretch Forward** and **FL-2 Wide-legged Spine Stretch Forward**.

### MOVEMENT

**START** - Exhale and reach forward with one hand on the opposite pedal. Hold other arm out to side. Inhale to prepare.

**MIDDLE** - Exhale to press pedal down while rotating free arm behind the body. Turn head and keep eyes on back hand.

**END** - Inhale to return pedals to top with slight de-rotation and repeat downward press.

### SEQUENCING

6-8 repetitions each side.

Medium speed throughout. (1-2 seconds down, 1-2 seconds up)

Aim to use the abdominal muscles to press and lift the pedals.

May bend knees slightly or sit on blocks if above positions are unachievable.

**Mat is not included.**



Wide-legged Alternating Arm Twist

# FL-6

## FLOOR EXERCISES

INTEGRATED

### Advanced Swimmer

**CAUTION**

**Shoulder issues (posterior dislocation, impingement, capsulitis)**

**SPRING POSITION**

**LOW OR HIGH  
MAT ON FLOOR**

**BODY POSITION**

As with **FL-4 Swimmer**.

**MOVEMENT**

**START** - Lift head and chest away from ground and reach the pedals one hand at a time until both are on each pedal. Float both straight legs away from the ground.

**MIDDLE** -Alternate the pedal push and leg kick, (pedal arm down, same leg up) Maintain the chest height evenly away from the ground in an extension position.

**SEQUENCING**

15-30 repetitions.

Start slowly and buildup speed. Only arms and legs move. Body stays still.

Aim to use the armpit area muscles to press and lift the pedals.

Mat is not included.



**FL-7****FLOOR EXERCISES****BAND****Full Body Roll Down****CAUTION**

- **Severe/acute disc herniation**
- Make sure that you are using the bands in a manner that reduces your risk of injury. Wear eye protection such as goggles or glasses while using resistance bands for exercise.

**BAND POSITION & STRENGTH**

**BASE CONNECTORS** – Loop band on both connectors.  
**MEDIUM BAND**  
**MAT BEHIND CHAIR**

**BODY POSITION**

Sit on ground facing "TOWARD" the chair, legs straight.  
 Take the band in the hands about shoulder width apart, elbows slightly bent.

**MOVEMENT**

**START** – Sitting tall, exhale, scoop the belly in and begin to lay backwards on the mat using the band to help control the speed.  
**MIDDLE** – When head reaches the ground, inhale and then exhale - the band will be at maximum stretch and help you roll back up to seated.  
**END** – Once at the sitting position, straighten back and sit tall then repeat.

**SEQUENCING**

6-10 repetitions.  
 Slow and even speed throughout. (4 seconds up and 4 seconds down)  
 Articulate the spine one vertebrae at a time.  
 Aim for a smooth "peeling" motion.

**VARIATIONS**

**"Rotated Rolldown"** – Turn the head and shoulders to one side and roll down one side of the spine. Can roll up the same side or change at the bottom to the other side.

**Mat and Band is not included.**



Full Body Roll Down with Spine Twist



## FL-8

## FLOOR EXERCISES

## BAND

## Resistance Band Full Body Roll Up

## CAUTION

- **Severe/acute disc herniation**
- Make sure that you are using the bands in a manner that reduces your risk of injury. Wear eye protection such as goggles or glasses while using resistance bands for exercise.

BAND  
POSITION &  
STRENGTH

**BASE CONNECTORS** – Loop band on both connectors.  
**MEDIUM BAND**  
**MAT BEHIND CHAIR**

## BODY POSITION

Lie on the ground face up, head near chair.

Take the band in the hands about shoulder width apart and hold straight toward the ceiling.

## MOVEMENT

**START** – Exhale and begin to lift the head and arc the hands over toward the feet as you roll up to seated position.

**MIDDLE** – Sit tall and hold the arms straight out in front of you at shoulder height or raise even higher. Inhale.

**END** – Exhale and roll down as slowly as possible.

## SEQUENCING

6-10 repetitions.

Slow and even speed throughout. (4-6 seconds up and 4-8 seconds down)

Articulate the spine one vertebrae at a time.

Aim for a smooth "peeling" motion.

Adjust the angle of the arms to change the difficulty. (arms more in line with ears is harder)

## VARIATIONS

**“Rotated Rollup”** – Turn the shoulders and eyes slightly to one side and roll up and down one side of the spine only as with above Rotated Rolldown variation. (not shown)

Mat and Band is not included.



## FL-9

## FLOOR EXERCISES

## BAND

## Resistance Band Rear Delt Row

## CAUTION

Make sure that you are using the bands in a manner that reduces your risk of injury. Wear eye protection such as goggles or glasses while using resistance bands for exercise.

BAND  
POSITION &  
STRENGTH

**BASE CONNECTORS** - Loop band on both connectors.  
**MEDIUM BAND**  
**MAT BEHIND CHAIR**

## BODY POSITION

Sit on ground facing "TOWARD" the chair, legs straight ahead or open-V.

Take the band in the hands palms down about shoulder width apart, arms straight.

## MOVEMENT

**START** - Sitting tall, inhale as you slowly row the hands back toward the shoulders by squeezing the elbows backwards.

**MIDDLE** - Keep the elbows and wrists the same width and squeeze shoulder blades together slightly.

**END** - Exhale and release back to the start position.

## SEQUENCING

10-15 repetitions.

Slow and even speed throughout. (2-3 seconds in and 1-2 seconds back)

Angle the arms so that you can keep your shoulders down and minimize neck muscle (upper trapezius) involvement.

Focus on the sensation of squeezing the elbow and shoulder blades backwards.

## VARIATIONS

**"Rotated Rows"** - Toward the end of the row in, slightly rotate the head and shoulders to one side.

Mat and Band is not included.

Rear Delt Row



Rear Delt Row with Spine Twist

# FL-10

## FLOOR EXERCISES

### BAND

## Resistance Band Chest & Overhead Press

### CAUTION

Make sure that you are using the bands in a manner that reduces your risk of injury. Wear eye protection such as goggles or glasses while using resistance bands for exercise.

### BAND POSITION & STRENGTH

**BASE CONNECTORS** – Loop band on both connectors.  
**MEDIUM BAND**  
**MAT BEHIND CHAIR**

### BODY POSITION

Sit on ground facing "AWAY" from the chair, legs straight ahead, open-V or crossed.

Loop band over the head in front of the chest.

Take the band in the hands palms down about shoulder width apart, elbows bent, strap touching chest.

### MOVEMENT

**START** – Sitting tall, exhale as you press forward. (like a bench press or press-up)

**MIDDLE** – Fully extend the arms forward, parallel to the ground.

**END** – Inhale, bend the elbows and return to the starting position.

### SEQUENCING

10-15 repetitions.

Slow and even speed throughout. (2-3 seconds in and 1-2 seconds back)

### VARIATIONS

**“Press and Raise”** – At the fully straight position, slowly raise the arms toward the ceiling with an inhale, exhale back to parallel, return or repeat x 3.

**“Rotate”** – Add a rotation into the movement during the press.

Mat and Band is not included.

### Resistance Band Chest Press

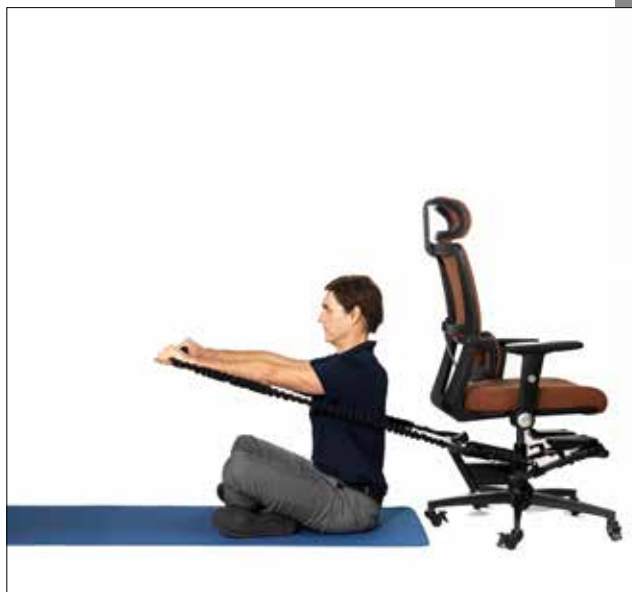

### Resistance Band Over Head Press



### Resistance Band Over Head Press with Rotation

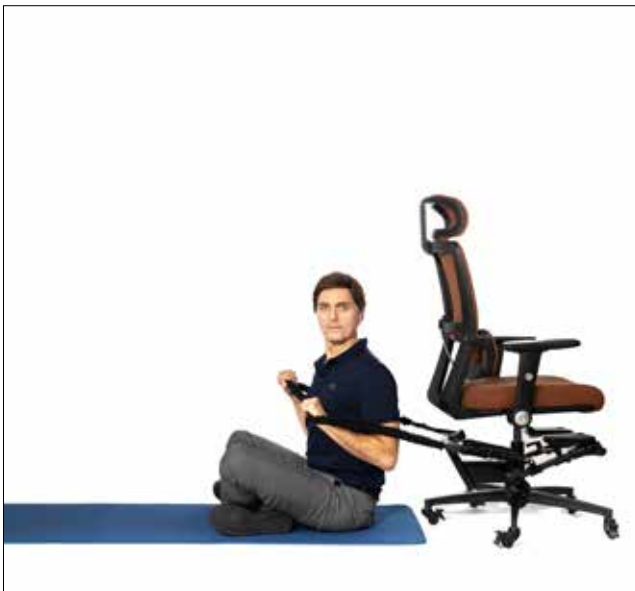

## FL-11

## FLOOR EXERCISES

## BAND

## Kneeling Side Bend

## CAUTION

Make sure that you are using the bands in a manner that reduces your risk of injury. Wear eye protection such as goggles or glasses while using resistance bands for exercise.

BAND  
POSITION &  
STRENGTH

**BASE CONNECTORS** – Loop band on both connectors.  
**MEDIUM BAND**  
**MAT BEHIND CHAIR**

## BODY POSITION

Sit on ground "SIDEWAY" 3-4' away from chair, legs crossed. Kneeling position can also be used. (below)  
Hold single band in chair side hand at shoulder height. Other arm reaches out to side, away from chair.

## MOVEMENT

**START** – Inhale to sit tall, exhale to lean away from chair, bringing side hand down to lightly touch the ground.  
**MIDDLE** – Press the band hand up toward ceiling and over head.  
**END** – Inhale, to simultaneously return to start position.

## SEQUENCING

6-8 repetitions each side.  
Slow and even speed throughout. (2-4 seconds in and 2-4 seconds back)

## VARIATIONS

**"Side Arm pumps"** – At the fully side bending position, bend and straighten the elbow 3-5 times like a shoulder press.

Mat and Band is not included.

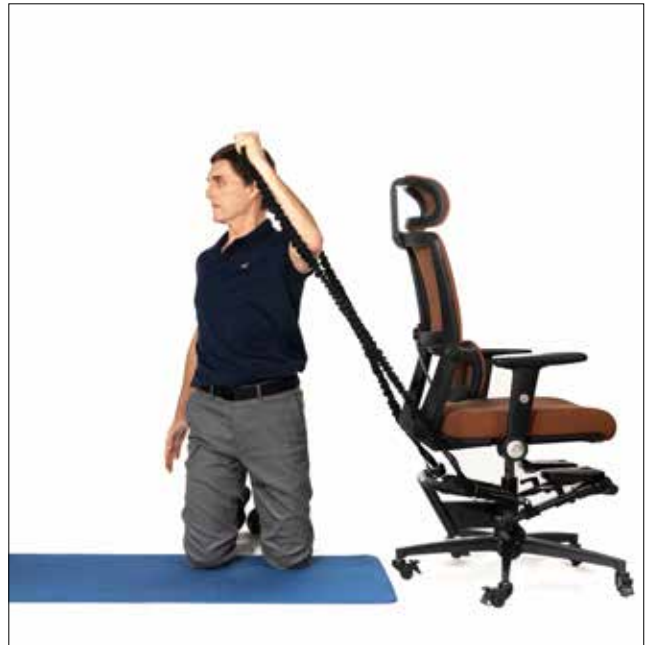

Kneeling Side Bend with Spine Rotation

# MY SMARTFIT CHAIR

MY  
SMARTFIT  
CHAIR



CONTACT NUMBER : 833-621-0432  
ADDRESS : 3701 Yale Street, Houston, Texas 77018